

Precision rolled ball screws

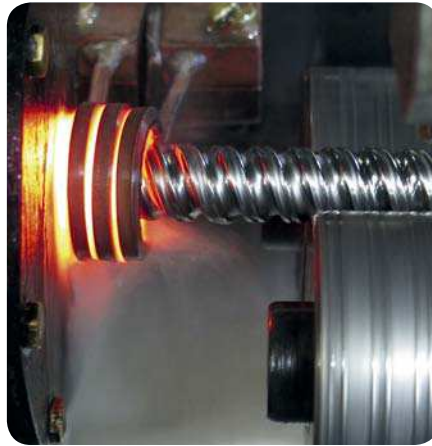



Contents

A Recommendations for selection

SKF – the knowledge engineering company	4
Product overview	6
Technical concepts	8
Introduction to SKF ball screws	8
Basic dynamic load carrying capacity (C_a)	8
Nominal fatigue life L_{10}	8
Service life	8
Equivalent dynamic load	8
Basic static load carrying capacity (C_{0a})	9
Critical rotating speed for screw shafts	9
Permissible speed limit	9
Screw shaft buckling	9
Lubrication	9
Efficiency and back-driving	10
Axial play and preload	10
Static axial stiffness of a complete assembly	10
Materials, heat treatment and coatings	11
Operating temperature	11
Ball screw support bearings	11
Designing the screw shaft ends	11
Critical applications	11
Working environment	11

B Recommendations for assembly

Assembly procedure	12
Storage	12
Alignment	12
Lubrication	12
Removing the nut / assembling the nut on the shaft	12
Wipers assembly	12
Starting-up the screw	12

C Lead precision

Manufacturing precision	14
High precision rolled ball screws	14
Lead precision	15

D Product information

SD/BD/SH miniature screws	16
SDS/BDS/SHS miniature screws in stainless steel	18
SX/BX universal screws	20
Dedicated flanges for SX/BX nuts	22
SND/BND precision screws, DIN standard 69051	24
PND preloaded screws, DIN standard 69051	26
SN/BN precision screws	28
PN preloaded screws	30
SL/TL long lead screws	32
SLT/TLT rotating nut	34
Shaft end combinations	36
Standard machined ends	37
Ball screw support bearings	42
Examples of customized nuts	48
Manufacturing tolerances	49
Calculation formulae	50

E Service range

54

F Design calculation and inquiry form

56

Designation system	58
--------------------------	----

G SKF Linear Motion

Rollers screws, electromechanical cylinders and guiding solutions	59
--	----

SKF – the knowledge engineering company

From one simple but inspired solution to a misalignment problem in a textile mill in Sweden, and fifteen employees in 1907, SKF has grown to become a global industrial knowledge leader.



Over the years we have built on our expertise in bearings, extending it to seals, mechatronics, services and lubrication systems. Our knowledge network includes 46 000 employees, 15 000 distributor partners, offices in more than 130 countries, and a growing number of SKF Solution Factories around the world.

Research and development

We have hands-on experience in over forty industries, based on our employees' knowledge of real life conditions. In addition our world-leading experts and university partners who pioneer advanced theoretical research and development in areas including tribology, condition monitoring, asset management and bearing life theory. Our ongoing commitment to research and development helps us keep our customers at the forefront of their industries.

Meeting the toughest challenges

Our network of knowledge and experience along with our understanding of how our core technologies can be combined helps us create innovative solutions that meet the toughest of challenges. We work closely with our customers throughout the asset life cycle, helping them to profitably and responsibly grow their businesses.

Working for a sustainable future

Since 2005, SKF has worked to reduce the negative environmental impact from our own operations and those of our suppliers. Our continuing technology development introduced the SKF BeyondZero portfolio of products and services which improve efficiency and reduce energy losses, as well as enable new technologies harnessing wind, solar and ocean power. This combined approach helps reduce the environmental impact both in our own operations and in our customers'.



SKF Solution Factories make SKF knowledge and manufacturing expertise available locally, to provide unique solutions and services to our customers.



Working with SKF IT and logistics systems and application experts, SKF Authorized Distributors deliver a valuable mix of product and application knowledge to customers worldwide.



Our knowledge – your success

SKF Life Cycle Management is how we combine our technology platforms and advanced services, and apply them at each stage of the asset life cycle, to help our customers to be more successful, sustainable and profitable.

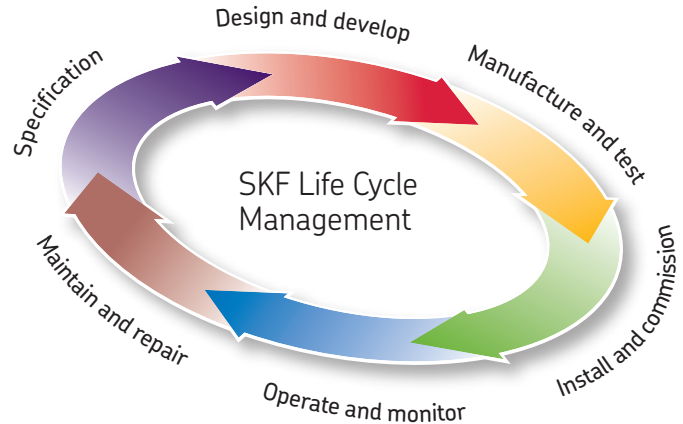

Working closely with you

Our objective is to help our customers improve productivity, minimize maintenance, achieve higher energy and resource efficiency, and optimize designs for long service life and reliability.



Bearings

SKF is the world leader in the design, development and manufacture of high performance rolling bearings, plain bearings, bearing units and housings.

Innovative solutions

Whether the application is linear or rotary or a combination of the two, SKF engineers can work with you at each stage of the asset life cycle to improve machine performance by looking at the entire application. This approach doesn't just focus on individual components like bearings or seals. It looks at the whole application to see how each component interacts with the next.



Machinery maintenance

Condition monitoring technologies and maintenance services from SKF can help minimize unplanned downtime, improve operational efficiency and reduce maintenance costs.

Design optimization and verification

SKF can work with you to optimize current or new designs with proprietary 3-D modeling software that can also be used as a virtual test rig to confirm the integrity of the design.



Sealing solutions

SKF offers standard seals and custom engineered sealing solutions to increase uptime, improve machine reliability, reduce friction and power losses, and extend lubricant life.



Mechatronics

SKF fly-by-wire systems for aircraft and drive-by-wire systems for off-road, agricultural and forklift applications replace heavy, grease or oil consuming mechanical and hydraulic systems.



Lubrication solutions

From specialized lubricants to state-of-the-art lubrication systems and lubrication management services, lubrication solutions from SKF can help to reduce lubrication related downtime and lubricant consumption.



Actuation and motion control

With a wide assortment of products – from actuators and ball screws to profile rail guides – SKF can work with you to solve your most pressing linear system challenges.

Product overview

Screw assembly



SD/BD – SDS/BDS



SH – SHS



SX/BX



SND/BND/PND, DIN 69051

Type of recirculation



Internal, by inserts
Stainless steel optional ¹⁾



External, by integrated tube
Stainless steel optional ²⁾



Internal, by inserts



Internal, by inserts

Designation	d ₀	P _h	Page
	mm	mm	
SD/BD/SDS/BDS	8	2,5	16
SD/BD/SDS/BDS	10	2	
SD/BD	10	4	18
SD/BD/SDS/BDS	12	2–4–5	
SD/BD/SDS/BDS	14	4	
SD/BD/SDS/BDS	16	2–5	
SD/BD	16	10	
SH/SHS	6	2	
SH	10	3	
SH	12,7	12,7	
SX/BX	20	5	
SX/BX	25	5–10	
SX/BX	32	5–10	
SX/BX	40	5–10–40	
SX/BX	50	10	
SX/BX	63	10	
SND/BND/PND	16	5–10	20
SND/BND/PND	20	5	
SND/BND/PND	25	5–10	
SND/BND/PND	32	5–10	
SND/BND/PND	40	5–10	
SND/BND/PND	50	10	
SND/BND/PND	63	10	

¹⁾ except 10×4 R and 16×10 R
²⁾ 6×2 R only.

Screw assembly



SN/BN/PN

Type of recirculation

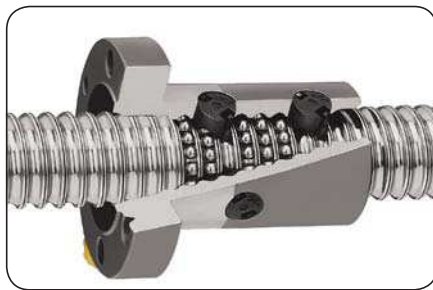

Internal, by inserts



SL/TL – SLD/TLD



By faces



SLT/TLT rotating nuts

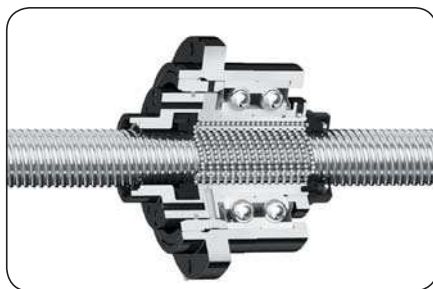

By faces



Ball screw support bearings FLBU, PLBU, BUF



Complete ball screw assembly with support bearing

Designation	d ₀	P _h	Page
	mm	mm	
SN/BN/PN	16	5	28
SN/BN/PN	20	5	
SN/BN/PN	25	5–10	
SN/BN/PN	32	5–10	
SN/BN/PN	40	5–10	
SN/BN/PN	50	10	
SN/BN/PN	63	10	
SL/TL	25	20–25	32
SL/TL	32	20–32–40	
SLD/TLD	32	32	
SL/TL	40	20–40	
SL/TL	50	50	
SLT/TLT	25	20–25	34
SLT/TLT	32	20–32–40	
SLT/TLT	40	20–40	
SLT/TLT	50	50	
FLBU/PLBU/BUF	16		44
FLBU/PLBU/BUF	20		
FLBU/PLBU/BUF	25		
FLBU/PLBU/BUF	32		
FLBU/PLBU/BUF	40		
FLBU/PLBU/BUF	50		
FLBU/PLBU/BUF	63		

Technical concepts

Introduction to SKF ball screws

This catalogue describes SKF expertise, technology and solutions related to precision rolled ball screws. Thanks to our lengthy experience with manufacturing ball screws and continuous product and process development, SKF provides customers with precision rolled ball screw solutions that fulfil their most demanding applications in terms of efficiency, precision, durability and value.

In many cases, these ball screws can replace ground ball screws, offering a similar level of performance and precision at a lower cost.

The high quality of SKF rolled ball screws is achieved through our dedicated manufacturing processes, including precision rolling and specific heat-treatment.

Ball screws convert rotary motion into linear motion, and vice-versa, and loads are transferred from the screw shaft to the nut through a ball set: in this sense, ball screws relate to general bearing technology. Various types of bearing steel are used to attain the hardness and material fatigue properties required for carrying heavy application loads over extended periods of service. Some bearing concepts such as load ratings, load cycles, nominal and service life, stiffness, speed ratings, lubrication requirements, etc. are explained below to guide customers through the ball screw selection process.

Only basic selection parameters are included in this chapter. To make the very best selection of a ball screw, the designer should

consider critical parameters such as the load cycle, the linear or rotational speed, the rates of acceleration and deceleration, the cycle rate, the environment, the required life, the lead accuracy, the stiffness, and any other special requirements. If in doubt, please consult the SKF ball screw assembly specialists who will assist you in the selection process.

Basic dynamic load carrying capacity (C_a)

The dynamic load rating capacity is used to compute the nominal fatigue life of ball screws. It results from the axial load, constant in magnitude and direction, which acts along the central axis of the ball screw, resulting in the calculated nominal life as defined by ISO of one million revolutions.

With a given combination of nominal diameter and lead, a ball screw's dynamic and static load carrying capacities are determined by the number of ball turns supporting the load.

For each product family, the type and number of circuits generate a specific number of ball turns. For example, the SH type nut with external tube recirculation typically presents 2,5 turns of balls within a circuit. The standard SD type nut has 3 circuits covering 0,9 turns each.

Nominal fatigue life L_{10}

Nominal fatigue life is, according to the ISO definition, the life achieved or exceeded by 90% of a large-enough group of apparently identical ball screws, working under identical conditions (alignment, axially and centrally applied load, speed, acceleration, lubrication, temperature and cleanliness).

The nominal life of a ball screw is the statistical number of revolutions which the ball screw is capable of reaching before the first signs of material fatigue by flaking occur on one of the rolling surfaces.

Service life

The actual life achieved by a specific ball screw before it fails is known as "service life." Failure is due not only to material fatigue by flaking, but also to inadequate lubrication, wear of the recirculation system, corrosion, contamination and, more generally, loss of the functional characteristics required by the application.

Experience acquired with similar applications will help in selecting the right screw to obtain the necessary service life. Structural requirements such as the strength of screw ends and nut attachments should be considered.

To attain L_{10} life performance, a mean working load of up to 60% of C_a (to limit the Hertz pressure at the balls / raceways contacts) and a stroke higher than 4 leads (to avoid false-brinelling which could occur with very short strokes or oscillation movements) are required.

Equivalent dynamic load

The loads acting on the screw can be calculated according to the laws of mechanics if the external forces (e.g. power transmission, work, rotary and linear inertia forces) are known or can be calculated. It is necessary to calculate the equivalent dynamic load.

Radial and moment loads must be taken up by linear bearing systems. It is extremely important to resolve these problems at the earliest possible design stage. These forces are detrimental to the life and the expected performance of the screw (→ fig. 1).

When the load fluctuates during the working cycle, it is necessary to calculate the equivalent dynamic load: this load is defined as the hypothetical load, constant in magnitude and direction, acting axially and centrally on the screw, which if applied, would have the same influence on the screw life as the actual loads which the screw is subjected to.

If misalignment, uneven loading, shocks, etc. cannot be avoided in the application,

Life test bench



they must be taken in account during the sizing of the ball screw.

Their influence on the screw's nominal life can generally be estimated¹⁾.

Basic static load carrying capacity (C_{0a})

Ball screws should be selected considering the basic static load capacity C_{0a} , rather than the basic dynamic load capacity, when they are subjected to continuous or intermittent shock loads while stationary or rotating at very low speed for short periods of time. The permissible load is determined by the permanent deformation caused by the load acting at the contact points.

The static load carrying capacity is, according to ISO standards, the purely axially and centrally applied static load which creates, by calculation, a total (rolling element + threaded surface) permanent deformation equal to 0.0001 times the diameter of the rolling element (→ fig. 2).

A ball screw basic static load rating must be, at a minimum, equal to the product of the maximum axial static load applied and a safety factor " s_0 ." Past experience with similar applications and requirements of running smoothness and noise level will guide the selection of " s_0 "¹⁾.

Critical rotating speed for screw shafts

For this calculation, the shaft is equated to a cylinder, with an external diameter equal to the root diameter of the thread. The formulae use a parameter whose value is dictated by the mounting of the screw shaft, whether it is simply supported or fixed.

As a general rule, the nut is not considered to be a support of the screw shaft. Because of the potential inaccuracies in the mounting of the screw assembly, a safety factor of 0,8 is applied to the calculated critical speed.

Calculations which consider the nut to be a support for the shaft, or which reduce the safety factor, require practical tests and possibly optimization of the design.

Permissible speed limit

The permissible speed limit is the speed which a screw cannot reliably exceed at any time. It is generally the limiting speed of the recirculation system in the nut. It is expressed as the product of maximum rotational speed (in rpm) and the nominal diameter of the screw shaft (expressed in mm).

The speed limits quoted in this catalogue (→ page 48) are the maximum speeds that may be applied for very short periods of time and with optimized running conditions of alignment, light external load and preload with monitored lubrication.

Running a screw continuously at the permissible speed limit may lead to a reduction of the calculated life of the nut mechanism.

Important!

High speed associated with high load requires a large input torque and yields a relatively short nominal life¹⁾.

In the case of high acceleration and deceleration, we recommend either working under a nominal external load or applying a light preload to the nut to avoid internal sliding during reversal of movement.

The preload for screws subjected to high velocity must be calculated to ensure that the rolling elements do not slide¹⁾.

Excessive preload will create an unacceptable increase in the internal temperature.

Screw shaft buckling

The column loading of the screw shaft must be checked when it is subjected to dynamic or static compression loading.

The maximum permissible compressive load is calculated using the Euler formulae, with a safety factor of 3 to 5, depending on the application.

The type of shaft end mounting is critical to select the proper coefficients to be used in the Euler formulae.

When the screw shaft has a single diameter along its total length, the root diameter of the threaded shaft is used for the calculation. When the screw comprises different sections with varying diameters, calculation becomes more complex¹⁾.

Lubrication

Proper quantities and quality of lubrication must be selected if ball screws are to operate correctly and to maximize their service life.

Greater care is required for operation at high speed, as the lubricant spread on the surface of the screw shaft may be thrown off by centrifugal forces. It is important to monitor this phenomenon during the first run at high speed and, if necessary, to adapt the frequency of re-lubrication or the flow of lubricant, or to select a lubricant with a different viscosity.

Monitoring the steady temperature reached by the nut allows for the optimization of the frequency of re-lubrication or the oil flow rate.

SKF SYSTEM 24 automatic lubrication kit can be adapted to most precision rolled ball screws.

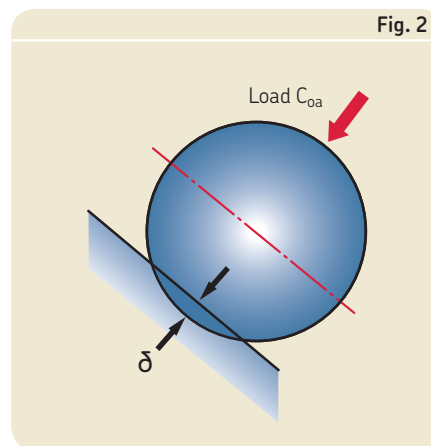
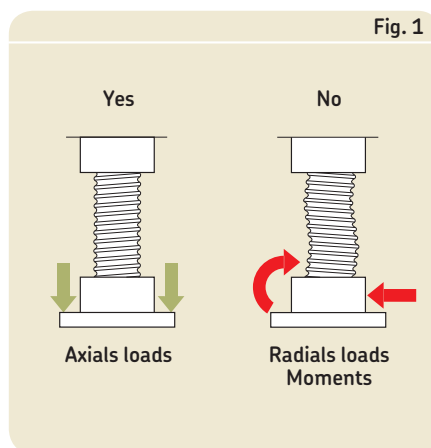

¹⁾ SKF can help you make these calculations with consideration to the actual conditions of service.

Efficiency and back-driving

Screw performance primarily depends on the geometry of the contact surfaces and their finish and the helix angle of the thread. It also depends on the working conditions (load, speed, lubrication, preload, alignment, etc.).

“Direct efficiency” is used to define the input torque required to transform the rotation of one component into the translation of the other. Conversely, “indirect efficiency” is used to define the axial load required to transform the translation of one component into the rotation of the other one. It is also used to define the braking torque required to prevent that rotation.

It is safe to assume that ball screws are reversible or back-driveable under almost all circumstances. A braking mechanism (gear reducers or brake) must be part of the design, if back-driving is to be avoided.

Preload torque

Screws with internal preload exhibit a certain amount of friction torque. This torque still exists when ball screws are not externally loaded. Preload torque is measured with ISO grade 64 oil.

Starting torque

This is the amount of torque required to overcome the following forces to start rotation:

- a** the total inertia of all moving parts accelerated by the source of power (including rotational and linear movements);
- b** the internal friction of the screw / nut assembly, bearings and associated guiding devices.

In general, the torque required to overcome the inertia (**a**) is greater than the friction torque (**b**). The friction coefficient of the high efficiency screw when starting moving (μ_s) is estimated to reach up to double the amount of the dynamic coefficient μ , under normal conditions of usage.

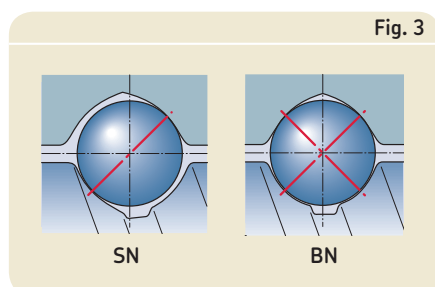

Axial play and preload

SKF products are available with a range of versions of axial play.

Standard axial play is intended for transport screws, when the product is not subject to vibrations, high accelerations, and when positioning accuracy under load is not critical (e.g.: SN type).

Reduced play (e.g.: SN type with reduced play) and backlash elimination by oversized balls (e.g.: BN type) are recommended to increase assembly precision (→ fig. 3).

For optimum stiffness and positioning accuracy under load, internally preloaded nuts are recommended (e.g.: PN type) (→ fig. 4). When subjected to external loading, preloaded nuts exhibit a much lower elastic deformation than non-preloaded nuts.

Preload is the amount of force applied to a set of two half-nuts necessary to either press them together or to push them apart with the purpose of eliminating backlash or increasing the stiffness of the assembly. The preload is measured by the value of the preload torque (see explanations in the previous paragraph). For a given amount of preload (expressed in Newton), the friction torque varies with different types of nuts and with the preloading method. The friction torque due to preload is indicated in product tables.

Static axial stiffness of a complete assembly

The static axial stiffness of a complete ball screw assembly is the ratio of the external axial load applied to the system and the axial displacement of the face of the nut in relation to the fixed (anchored) end of the screw shaft. Please see calculation formulae (→ pages 48 to 49).

Nut stiffness: R_n

When a preload is applied to a split nut, the internal play is eliminated. Additionally, the Hertzian elastic deformation increases with increased preload and increased stiffness.

The theoretical elastic deformation at the contact points does not take into account machining inaccuracies, actual sharing of the load between the different contact surfaces, or elasticity of the nut and of the screw shaft. For this reason, the practical stiffness values given in the catalogue are lower than the theoretical values. They are determined by SKF assuming a preload of 8,5% C_a for screws with diameter up to 40 mm, and a preload of 7% C_a for screws with diameter greater than 40 mm, when applying an external axial load centred on the screw shaft and equal to twice the amount of preload.

Shaft stiffness: R_s

The elastic deformation of the screw shaft is proportional to its length and inversely proportional to the square of the root diameter.

According to the relative importance of the screw deformation, an excessive increase of nut preload and of the supporting bearings yields a limited increase of stiffness and noticeably increases the preload torque and therefore the running temperature.

Consequently, the preload stated in the catalogue for each screw dimension is optimal and should not be exceeded.

Please see calculation formulae (→ pages 48 to 49).

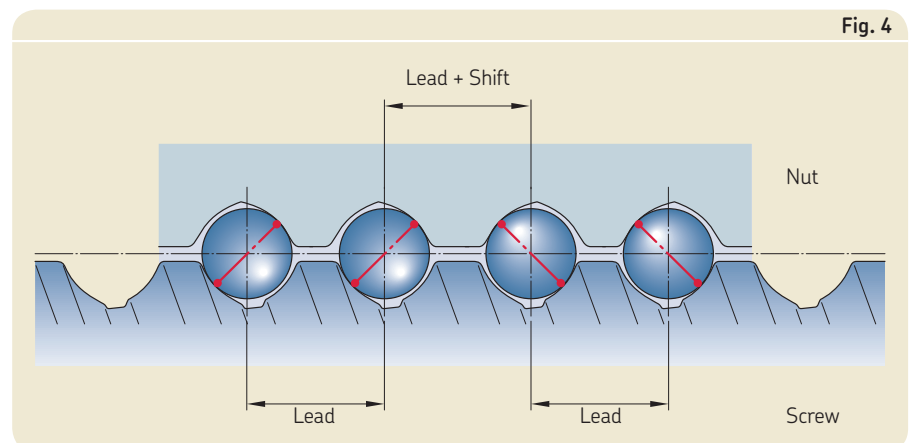

Materials, heat treatment and coatings

Standard screw shafts are manufactured from carbon steel which is surface hardened by induction. For standard screws, rolling surface hardness is 56 to 60 HRc, depending on diameter (for very small diameter screws, the temperature during the hardening process is slightly lowered to avoid the through-hardening of the screw shaft, therefore resulting in lower surface hardness).

Standard nuts are machined from steel which is through-hardened (100 Cr6–NFA 35.565 or equivalent for diameters ≥ 20 mm, and carbon steel for diameters < 20 mm).

Most stainless steel screws have a surface hardness ranging from 50 to 58 HRc, depending on the type of stainless steel being used and the screw diameter (note the effect of reduced hardening temperature on small diameter screws, as previously mentioned). The load ratings provided in the catalogue are given for standard screws only.

SKF offers various types of surface coating for improved ball screw performance:

- Manganese phosphate coating is standard for the SX/BX universal nuts. This coating can also be applied to most ranges of precision rolled ball screws to improve the resistance to corrosion
- Low friction coating or chrome coating are available on request. Please contact SKF.

Operating temperature

Screws made from standard steel and screws operating under normal loads can operate from -20 to $+110$ °C.

Between 110 °C and 130 °C, SKF must be notified for adaptation of the annealing procedure and for review of the application with hardness below the standard minimum value.

Above 130 °C, steel adapted to the temperature of the application should be selected (100Cr6, special steel, etc.). Please consult SKF for advice.

Operation at high temperatures will lower the steel hardness, alter the thread accuracy, may increase the oxidation of the materials and change the lubricant properties.

Ball screw support bearings

To assist the customer design and machinery assembly process, SKF has developed a range of support bearings specifically designed for ball screws with nominal diameter starting from 16 mm.

These support bearings can easily be mounted on the screw shaft ends, following SKF recommendations for ends machining (\rightarrow pages 36 to 41). Three types of support bearings available for fixed axial mounting (FLBU type in pages 42 to 43), for fixed radial mounting (PLBU type in pages 44 to 45) and for pure radial support (BUF type in pages 46 to 47), all fitted with SKF premium bearings, greased and sealed for life. SKF stocks these support bearings for quick delivery.

Designing the screw shaft ends

Generally speaking, when the ends of the screw shaft are specified by the customer's engineering staff, it is their responsibility to check the strength of these ends. However, we offer and recommend a choice of standard machined ends (pages 36 to 41).

Please bear in mind that no dimension on the shaft ends can exceed d_0 . Otherwise, traces of the root of the thread will appear. If the application requires a shaft end with a smooth surface of diameter greater than d_0 , it is advisable to add an additional part attached to the machined shaft end.

A minimum shoulder should be sufficient to maintain the bearing inner ring. Please follow bearing mounting recommendations.

Critical applications

The standard products have been fitted with composite ball recirculation inserts.

If the ball screws are used in severe applications, or if the inserts are used to prevent system collapse (especially in the case of vertical applications), optional steel inserts are available.

For critical applications, SKF also offers optional safety rings for miniature ball screws, and safety nuts for larger ball screws.

In such cases, the customer should consult SKF to define the optimum solution.

Working environment

Our products have not been developed for use in an explosive environment. Consequently, SKF cannot take any responsibility for the use of ball screws in such applications.

¹⁾ SKF can help you with these calculations, taking into account the working conditions.

Assembly procedure

Ball screw assemblies are precision components and should be handled with care to avoid damaging shocks, contamination or corrosion.

Storage

Storage location must ensure that ball screw assemblies are not exposed to contamination, shocks, humidity and other detrimental actions.

When stored out of the shipping crate, ball screw assemblies must lie on wooden or plastic V-shaped blocks and should not be allowed to bounce. The assembly must not be supported on the shelf by the nut body.

During shipping, ball screw assemblies are wrapped in heavy gauge plastic bags, which protect them from foreign material and possible contamination. They should remain wrapped until they are used.

Alignment

After assembly, any radial load or moment loading on the nut will overload some of the contact surfaces, thus significantly reducing the service life (→ **fig. 1**).

SKF linear guidance components should be used to ensure correct alignment and to avoid non-axial loading. The parallelism of the screw shaft with the guiding devices must be checked carefully. If external linear guidance proves impractical, we suggest mounting the nut on trunnions or gimbals, and mounting the screw shaft on self-aligning bearings.

Mounting the screw in tension helps to align it properly and eliminates buckling.

Lubrication

Good lubrication is essential for the proper operation and long term reliability of the ball screw assembly. If necessary, please consult SKF.

Before shipping, the complete ball screw assembly is coated with a protective fluid that dries to a film. This protective film is not a lubricant. Depending on the lubricant selected for the application, it may be necessary to remove the protective film before applying the lubricant in order to eliminate any risk of incompatibility. In such cases, we recommend the following procedure:

- 1 Dip the ball screw assembly into a solvent
- 2 Shake and rotate the assembly to allow the solvent to penetrate
- 3 Remove the assembly from the solvent and allow the solvent to drain.

Removing the nut / assembling the nut on the shaft

Removing the nut from the screw shaft

If possible, do not remove the nut from the shaft, especially for preloaded assemblies. If the nut must be removed from the shaft, i.e. for shaft end machining, check the nut orientation before disassembly.

Never unscrew the nut from the shaft without a mandrel or sleeve to prevent the balls from falling off the nut (→ **fig. 6**).

Once the nut is engaged on the sleeve, use a tie wrap to secure the nut assembly (→ **fig. 5**).

Fitting sleeved nut onto screw shaft

Sleeved nuts should not be removed from the sleeve until final assembly.

- 1 Remove the retaining strap (→ **fig. 5**)
- 2 Check the assembly drawing to confirm the nut orientation
- 3 Hold the sleeve against the ball track of the screw shaft and smoothly engage the ball nut (→ **fig. 6**)

If the sleeve does not cover the diameter next to the ball track (for example, the sleeve bore diameter is smaller than the screw shaft end), then adhesive tape can be used to match the shaft end to the sleeve outer diameter. Otherwise, the sleeve can be held against the unmachined end, if available, with extreme care to prevent the balls from falling off the nut

- 4 Without using force, completely engage the nut in the screw thread, and run the nut to full engagement on the screw shaft.

Wiper assembly

If optional wipers have been ordered, please refer to the fitting instructions enclosed with the shipment.

Starting-up the screw

After the assembly has been cleaned, fitted and lubricated, allow the nut to make several full strokes at low speed (< 50 rpm) and light load (not to exceed 5% of the ball screw dynamic carrying capacity) in order to check the proper positioning of the limit switches or reversing mechanism. Then, normal load and speed can be applied.

Note:

Instructions for most operations such as fitting a nut onto a screw shaft, a wiper onto a nut, etc. are available in separate sheets delivered with the product. Please refer to them before assembling the screw.

Fig. 5



B

Fig. 6

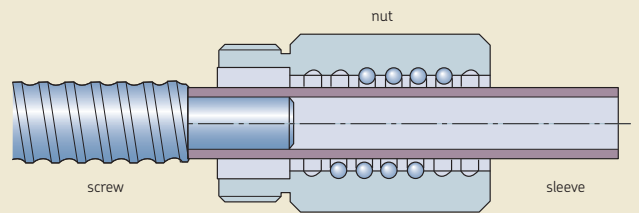

Notes

Grid area for notes.

Lead precision

Manufacturing precision

Generally speaking, the precision indicated defines the lead precision that complies with ISO standards, e.g. G5, G7, etc. (→ **table 1**). Parameters other than lead precision correspond to SKF internal standards, generally based on ISO class 7. If the application requires special tolerances, for example class 5, please specify these requirements in the inquiry.

SKF high precision rolled ball screws

High technology machinery associated with precise control of the cold forming and metallurgical processes results in screw production that virtually offers the same accuracy and performance level of ground ball screws, but at a lower cost (→ **diagram 1**). Standard lead precision is G9, which complies with ISO 286-2:1988. SKF production meets G7 lead precision for screw shaft diameters starting from $d_0 = 20$ mm. On request, SKF can deliver ball screws with G5 lead precision which are in accordance with ISO 3408-3:2006, defined for positioning screws and matching the lead precision of G5 ground ball screws.

Lead precision

Lead precision is measured at 20 °C on the useful stroke l_u . At SKF l_u is the threaded length of the shaft minus twice the length l_e equal to the screw nominal diameter (→ **table 1 and fig. 7**).

Some customer applications require a travel compensation c to account for the effect of operating temperature on the lead precision:

- Standard case with $c = 0$ (→ **fig. 8**)
- Case with specific value of c (→ **fig. 9**).

Diagram 1

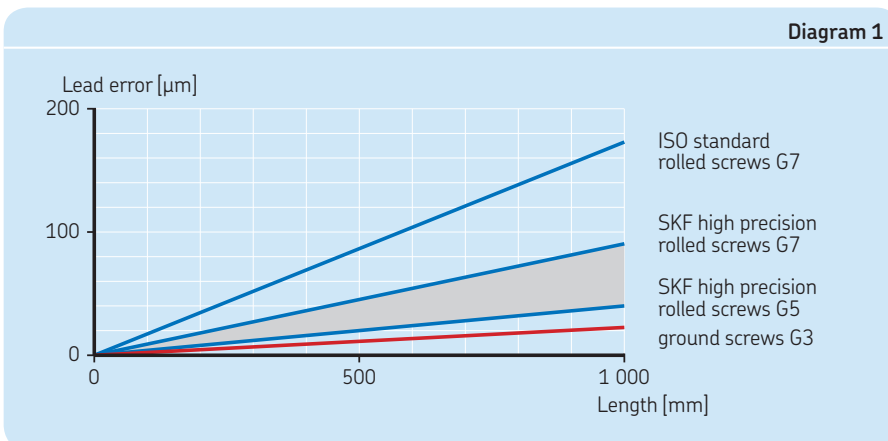
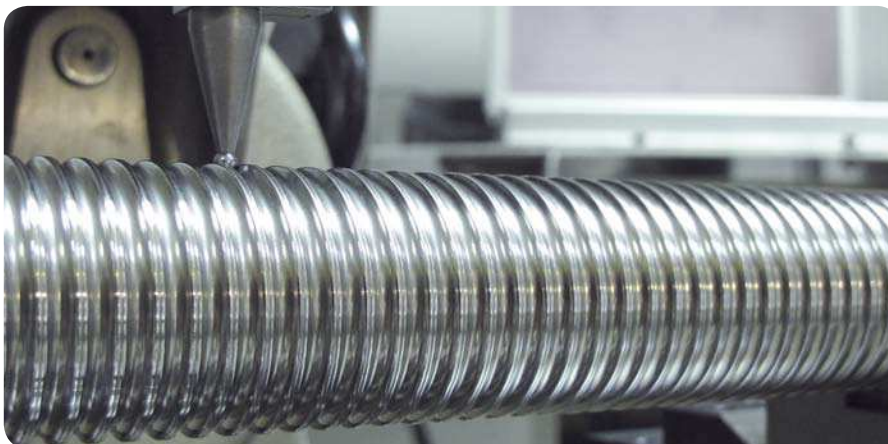

Table 1

V_{300p} l_u mm	G5		G7		G9	
	e_p	v_{up}	e_p	v_{up}	e_p	v_{up}
	µm					
0 – 315	23	23	52	35	130	87
(315) – 400	25	25	57	40	140	100
(400) – 500	27	26	63	46	155	115
(500) – 630	32	29	70	52	175	130
(630) – 800	36	31	80	57	200	140
(800) – 1 000	40	34	90	63	230	155
(1 000) – 1 250	47	39	105	70	260	175
(1 250) – 1 600	55	44	125	80	310	200
(1 600) – 2 000	65	51	150	90	370	230
(2 000) – 2 500	78	59	175	105	440	260
(2 500) – 3 150	96	69	210	125	530	310
(3 150) – 4 000	115	82	260	150	640	370
(4 000) – 5 000	140	99	320	175	790	440
(5 000) – 6 000	170	119	390	210	960	530



Lead precision measurement

Symbols used in figs. 7 to 9

- l_u = useful travel
- l_e = excess travel (no lead precision required)
- l_0 = nominal travel
- l_s = specified travel
- c = travel compensation (difference between l_s and l_0 to be defined by the customer)
- e_p = tolerance over the specified travel
- V = travel variation (or permissible band width)
- V_{300p} = maximum permitted travel variation over 300 mm
- V_{up} = maximum permitted travel variation over the useful travel l_u
- V_{300a} = measured travel variation over 300 mm
- V_{ua} = measured travel variation over l_u

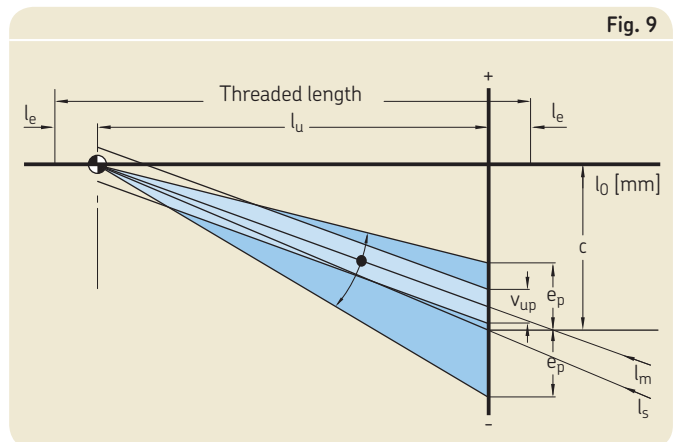
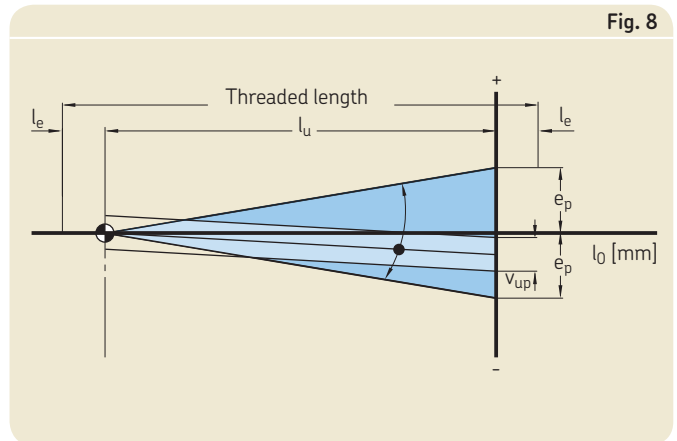
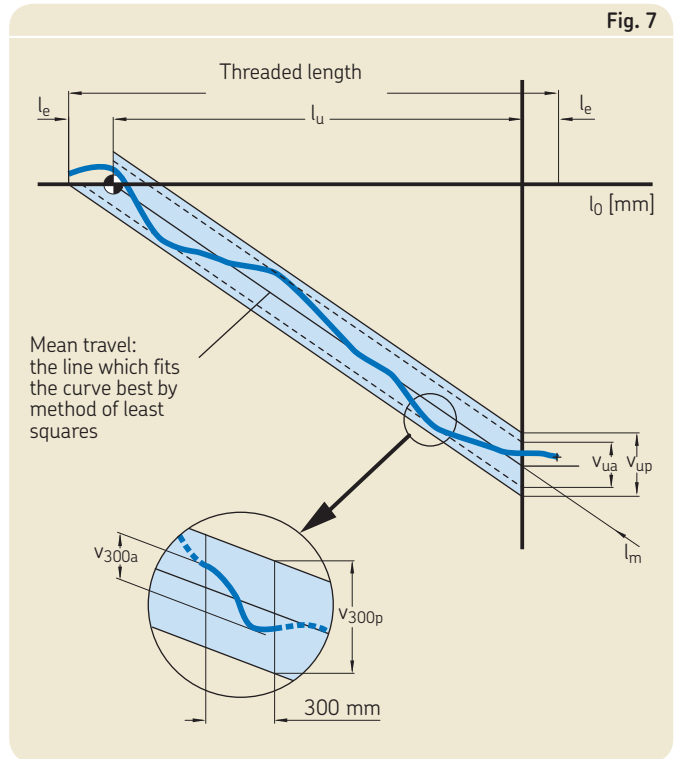

SD/BD/SH miniature screws

Rolled thread miniature ball screw, nut with threaded nose

Features

- Nominal diameter from 6 to 16 mm
- Lead from 2 to 12,7 mm
- Recirculation with inserts (SD/BD) or with tube (SH)
- Optional surface coating on shaft and nut
- Optional safety ring¹⁾
- Optional wipers²⁾ except 6x2 R – 10x3 R.

Benefits

- Excellent repeatability with high positioning accuracy
- Smooth running
- Extremely compact nut design with threaded nose for easy assembly
- Backlash elimination by oversized balls on request (BD designation), over maximum length of 1 000 mm.



Standard SD

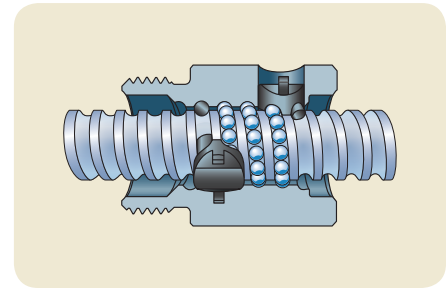

Recirculation SD/BD



Standard SH



Customised SD

Nominal diameter	Lead (right hand)	Nut		Number of circuits of balls	Std play	Reduced play on request	Inertia	Grease	Weight	Screw			Designation
		Basic load ratings dynamic	static							Mass	Inertia	Grease	
d_0	P_h	C_a	C_{oa}		mm		kgmm^2	cm^3	kg	kg/m	kgmm^2/m	cm^3/m	–
mm	mm	kN		–	mm		kgmm^2	cm^3	kg	kg/m	kgmm^2/m	cm^3/m	–
6	2	1,9	2,2	1x2,5	0,05	0,02	7,7	0,1	0,025	0,18	0,7	0,7	SH 6x2 R
8	2,5	2,2	2,7	3	0,07	0,03	1,12	0,1	0,025	0,32	2,1	1,1	SD/BD 8x2.5 R
10	2	2,5	3,6	3	0,07	0,03	1,7	0,1	0,03	0,51	5,2	1,4	SD/BD 10x2 R
	3	2,6	3,3	1x2,5	0,07	0,03	2,9	0,3	0,05	0,5	5,1	1,3	SH 10x3 R
	4	4,5	5,5	3	0,07	0,03	2,7	0,3	0,04	0,43	3,8	1,3	SD/BD 10x4 R
12	2	2,9	4,7	3	0,07	0,03	1,5	0,1	0,023	0,67	10	1,7	SD/BD 12x2 R
	4	4,9	6,6	3	0,07	0,03	7	0,4	0,066	0,71	10,8	1,6	SD/BD 12x4 R
	5	4,2	5,4	3	0,07	0,03	5	0,6	0,058	0,71	10,1	1,4	SD/BD 12x5 R
12,7	12,7	6,6	8,9	2x1,5	0,07	0,03	20	1,1	0,15	0,71	16,2	1,6	SH 12,7x12,7 R
14	4	6	9,1	3	0,07	0,03	8	0,6	0,083	1,05	22	1,7	SD/BD 14x4 R
16	2	3,3	6,2	3	0,07	0,03	9,2	0,6	0,1	1,4	39,7	1,7	SD/BD 16x2 R
	5	7,6	10,7	3	0,07	0,03	22,7	0,9	0,135	1,3	33,9	2,1	SD/BD 16x5 R
	10	10,7	17,2	2x1,8	0,07	0,03	24,4	1	0,16	1,21	30,7	1,9	SD/BD 16x10 R

¹⁾ Available for 12x4 R – 12,7x12,7 R – 14x4 R – 16x5 R – 16x10 R

²⁾ It is not possible to supply safety ring and wipers in the same nut

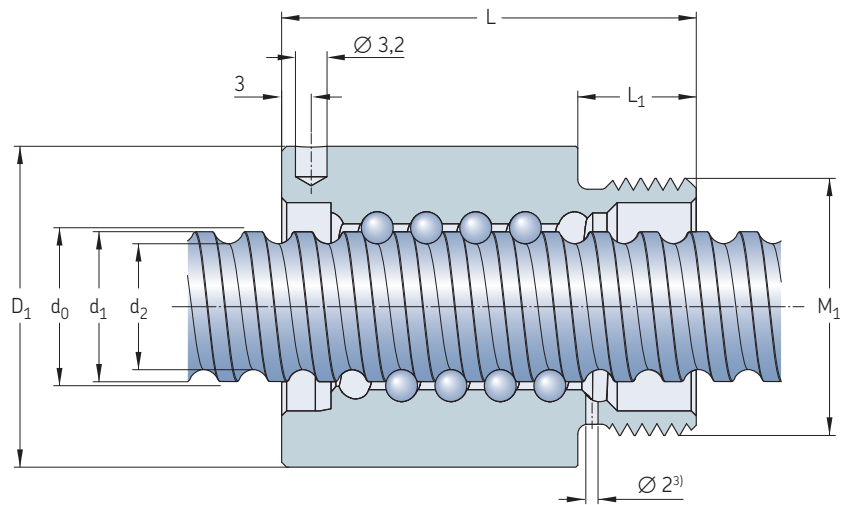

Screw	Nut		Without wiper	With wiper	Tightening spanner	Screw	Support bearing		Recommended thrust support bearings	Recommended support pillow block
	$d_0 \times P_h$	D_1 h10					M_1 6g	L $\pm 0,3$		
mm	mm	mm	mm	mm	mm	mm	mm	mm	mm	mm
6x2	16,5	M14x1	20	–	7,5	126-A35	1 000	4,7	6	
8x2,5	17,5	M15x1	23,5	23,5	7,5	126-A35	1 000	6,3	7,6	
10x2	19,5	M17x1	22	22	7,5	126-A35	1 000	8,3	9,5	
10x3	21	M18x1	29	–	9	126-A35	1 000	7,9	9,9	
10x4	21	M18x1	28	33	8	126-A35	1 000	7,4	8,9	
12x2	20	M18x1	20	23,5	8	126-A35	2 000	9,9	11,2	
12x4	25,5	M20x1	34	34	10	126-A35	2 000	9,4	11,3	
12x5	23	M20x1	36	40	10	126-A35	2 000	9,3	11,8	
12,7x12,7	29,5	M25x1,5	50	50	12	126-A35	2 000	10,2	13	
14x4	27	M22x1,5	30	34	8	126-A35	2 000	11,9	13,7	
16x2	29,5	M25x1,5	27	27	12	126-A35	2 000	14,3	15,5	FLBU 16/PLBU 16
16x5	32,5	M26x1,5	42	42	12	126-A35	2 000	12,7	15,2	FLBU 16/PLBU 16
16x10	32	M26x1,5	46	46	12	126-A35	2 000	12,6	15,2	FLBU 16/PLBU 16

SDS/BDS/SHS miniature screws in stainless steel

Rolled thread miniature ball screw, nut with threaded nose

Features

- Nominal diameter from 6 to 16 mm
- Lead from 2 to 5 mm
- Standard lead precision G7 and G9
- Material for shaft and nut is X30Cr13 (similar to AISI 420)
- Balls are made of stainless steel type X105CrMo17 (similar to AISI 440C)¹⁾
- Optional safety ring²⁾
- Optional wipers³⁾ except for SHS 6×2 R.



Standard SDS



Standard SHS

Benefits

- Excellent repeatability with high positioning accuracy
- Smooth running
- Extremely compact nut design with threaded nose for easy assembly
- Backlash elimination by oversized balls on request (BDS designation), over maximum length of 1 000 mm
- Suitable for long storage periods before customer usage, or for applications with extremely long service life
- Adapted for operation in clean environment.



Customised SDS

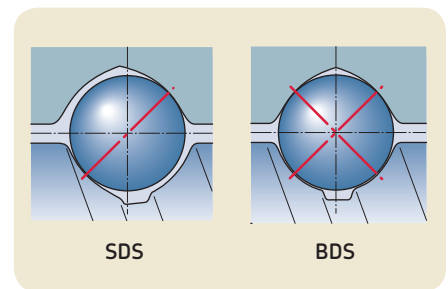

Nominal diameter	Lead (right hand)	Nut		Number of circuits of balls	Std play	Reduced play on request	Inertia	Grease	Weight	Screw			Designation
		Basic load ratings dynamic	static							Mass	Inertia	Grease	
d_0	P_h	C_a	C_{oa}		mm	mm	kgmm ²	cm ³	kg	kg/m	kgmm ² /m	cm ³ /m	–
mm	mm	kN	kN	–	mm	mm	kgmm ²	cm ³	kg	kg/m	kgmm ² /m	cm ³ /m	–
6	2	1,2	1,1	1×2.5	0,05	0,02	7,7	0,1	0,025	0,18	0,7	0,7	SHS 6×2 R
8	2,5	1,4	1,3	3	0,07	0,03	1,12	0,1	0,025	0,32	2,1	1,1	SDS/BDS 8×2,5 R
10	2	1,6	1,8	3	0,07	0,03	1,7	0,1	0,03	0,51	5,2	1,4	SDS/BDS 10×2 R
12	2	1,9	2,3	3	0,07	0,03	1,5	0,1	0,023	0,67	10	1,7	SDS/BDS 12×2 R
	4	3,1	3,3	3	0,07	0,03	7	0,4	0,066	0,71	10,8	1,6	SDS/BDS 12×4 R
	5	2,7	2,7	3	0,07	0,03	5	0,6	0,058	0,71	10,1	1,4	SDS/BDS 12×5 R
14	4	3,8	4,6	3	0,07	0,03	8	0,6	0,083	1,05	22	1,7	SDS/BDS 14×4 R
16	2	2,1	3,1	3	0,07	0,03	9,2	0,6	0,1	1,4	39,7	1,7	SDS/BDS 16×2 R
	5	4,8	5,4	3	0,07	0,03	22,7	0,9	0,135	1,3	33,9	2,1	SDS/BDS 16×5 R

¹⁾ Except for size SDS/BDS 16×5 R using steel type 100 Cr6 (similar to AISI 52100)

²⁾ Available for 12×4 R – 14×4 R – 16×5 R

³⁾ It is not possible to supply safety ring and wipers in the same nut

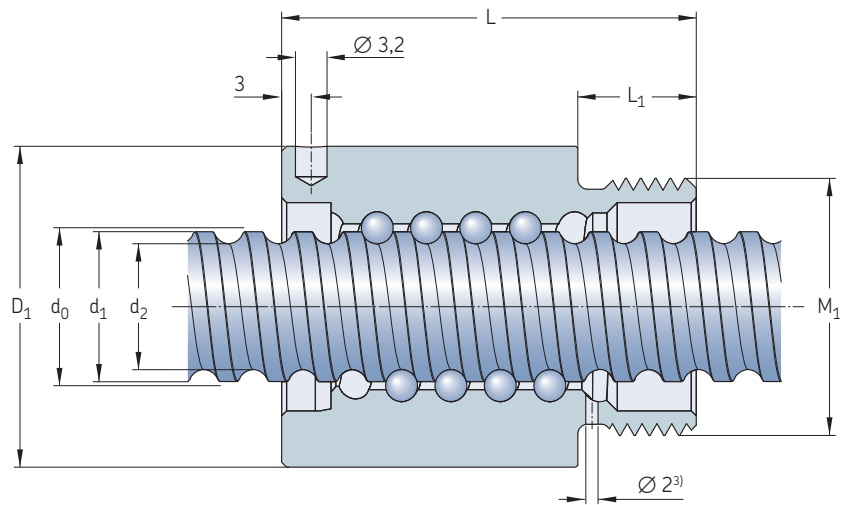

Screw $d_0 \times P_h$ mm	Nut		Without wiper L $\pm 0,3$ mm	With wiper L_1 mm	Tightening spanner (FACOM)	Screw length max. mm	d_2 mm	d_1 mm	Support bearing Recommended thrust support bearings	Recommended support pillow block
	D_1 h10 mm	M_1 6g mm								
6x2	16,5	M14x1	20	–	7,5	126-A35	1 000	4,7	6	
8x2,5	17,5	M15x1	23,5	23,5	7,5	126-A35	1 000	6,3	7,6	
10x2	19,5	M17x1	22	22	7,5	126-A35	1 000	8,3	9,5	
12x2	20	M18x1	23,5	23,5	8	126-A35	2 000	9,9	11,2	
12x4	25,5	M20x1	34	34	10	126-A35	2 000	9,4	11,3	
12x5	23	M20x1	40	40	10	126-A35	2 000	9,3	11,8	
14x4	27	M22x 1,5	34	34	8	126-A35	2 000	11,9	13,7	
16x2	29,5	M25x1,5	27	27	12	126-A35	2 000	14,3	15,5	FLBU 16/PLBU 16 ⁴⁾
16x5	32,5	M26x1,5	42	42	12	126-A35	2 000	12,7	15,2	FLBU 16/PLBU 16 ⁴⁾ BUF 16 ⁴⁾

⁴⁾ Support bearings with standard steel

SX/BX universal screws

Rolled thread ball screw with recirculation through inserts, nut with threaded nose

Features

- Nominal diameter from 20 to 63 mm
- Lead from 5 to 40 mm
- Standard composite recirculation inserts
- Optional steel recirculation inserts
- Lubrication hole for grease nipple or for SKF SYSTEM 24 automatic lubrication kit
- Phosphate coating on nut
- Optional shaft surface coating
- Optional safety nuts. Please contact SKF for selection and usage of this option
- Optional nut flanges (→ pages 22 to 23)
- Optional wipers.



Standard

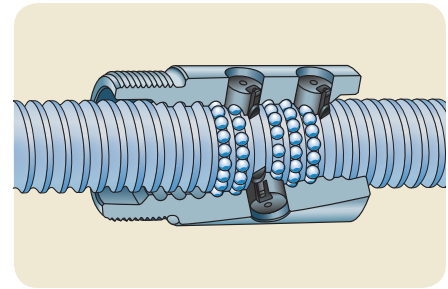

Recirculation

Benefits

- Minimum nut outside diameter and threaded nose for easy assembly
- Nut design well suited and economical for transport screw applications
- Optional steel recirculation inserts can act as a safety device for severe or vertical applications. Please contact SKF for such applications
- Backlash elimination by oversized balls on request (BX designation) for applications with vibrations / changes of direction, over maximum length of 1 000 mm.



Customised

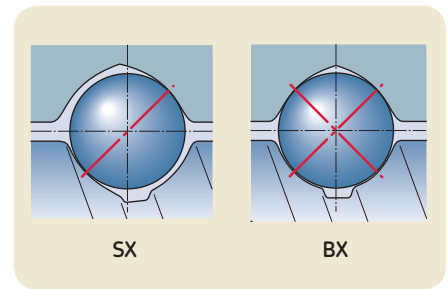

Nominal diameter	Lead (right hand)	Nut		Number of circuits of balls	Std play	Reduced play on request	Preload torque zero play T_{pr}	Inertia	Grease	Weight	Screw		Designation	
		Basic load ratings dynamic	static								Mass	Inertia	Grease	
d_0	P_h	C_a	C_{oa}		mm		Nm	kgmm ²	cm ³	kg	kg/m	kgmm ² /m	cm ³ /m	–
mm	mm	kN	–	–	mm		Nm	kgmm ²	cm ³	kg	kg/m	kgmm ² /m	cm ³ /m	–
20	5	14	23,8	4	0,1	0,05	0,1	60	1,3	0,24	2	85	2,7	SX/BX 20×5 R
25	5	19	37,8	5	0,1	0,05	0,17	125	2,5	0,39	3,3	224	3,4	SX/BX 25×5 R
	10	23,5	39	4	0,12	0,08	0,23	135	4,6	0,4	3,2	255	3,2	SX/BX 25×10 R
32	5	22	51,6	5	0,1	0,05	0,25	230	2,6	0,48	5,6	641	4,4	SX/BX 32×5 R
	10	27,1	52	4	0,12	0,08	0,32	400	5,9	0,77	5,6	639	3,7	SX/BX 32×10 R
40	5	24,3	65,6	5	0,1	0,05	0,34	390	3,3	0,58	9	1 639	5,6	SX/BX 40×5 R/L
	10	61,5	124,1	5	0,12	0,08	0,64	840	12,4	1,25	8,4	1 437	5	SX/BX 40×10 R
	40	31,3	72,9	2×1,9	0,1	0,05	0,64	1 200	14,4	1,6	8,1	1 330	5,2	SX/BX 40×40 R
50	10	80,4	188,8	6	0,12	0,08	1,02	2 400	19,9	2,4	13,6	3 736	6,3	SX/BX 50×10 R
63	10	91,2	248,3	6	0,12	0,08	1,44	4 620	25,4	3,1	22	9 913	8,1	SX/BX 63×10 R

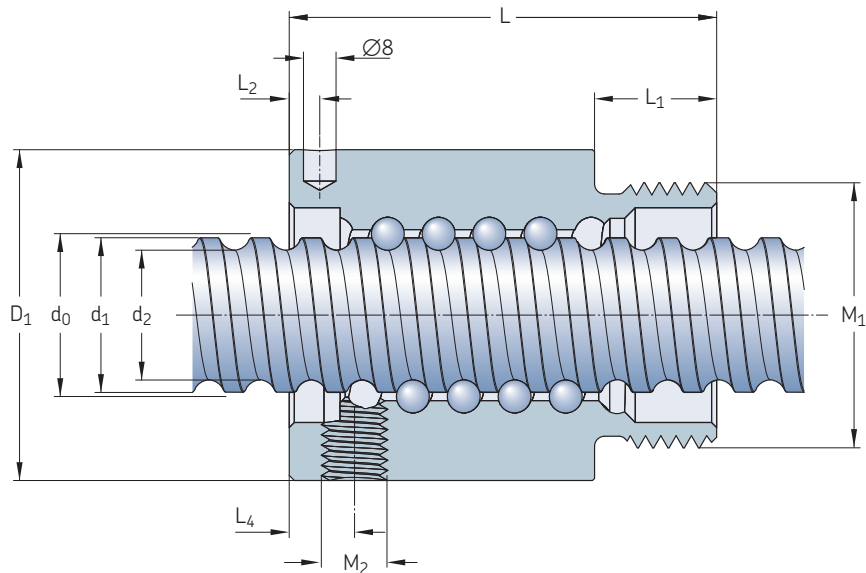

Screw $d_0 \times P_h$ mm	Nut D_1 $js13$ mm	M_1 6g	L	L_1	L_2	L_4	$M_2^{1)}$	Tightening spanner	Screw length max. mm	d_2	d_1	Support bearing Recommended thrust support bearings	Recommended support pillow block
20x5	38	M35x1,5	54	14	8	8	M6x1	HN5	4 700	16,7	19,4	PLBU 20/FLBU 20 ²⁾	BUF 20
25x5	43	M40x1,5	69	19	8	8	M6x1	HN6	4 700	21,7	24,6	PLBU 25/FLBU 25	BUF 25
25x10	43	M40x1,5	84	19	12	12	M6x1	HN6	4 700	20,5	24,6	PLBU 25/FLBU 25	BUF 25
32x5	52	M48x1,5	64	19	8	8	M6x1	HN7	5 700	28,7	31,6	PLBU 32/FLBU 32	BUF 32
32x10	54	M48x1,5	95	19	15	15	M6x1	HN7	5 700	27,8	32	PLBU 32/FLBU 32/FLRBU 3 ³⁾	BUF 32
40x5	60	M56x1,5	65	19	8	8	M6x1	HN9	5 700	36,7	39,6	PLBU 40/FLBU 40	BUF 40
40x10	65	M60x2	105	24	15	13	M8x1	HN9	5 700	34	39,4	PLBU 40/FLBU 40/FLRBU 4 ³⁾	BUF 40
40x40	65	M60x2	121	24	20	48,6	M8x1	HN9	5 700	34,2	38,3	PLBU 40/FLBU 40	BUF 40
50x10	78	M72x2	135	29	15	15	M8x1	HN12	5 700	44	49,7	PLBU 50/FLBU 50/FLRBU 5 ³⁾	BUF 50
63x10	93	M85x2	135	29	15	15	M8x1	HN14	5 700	57	62,8	PLBU 63/FLBU 63	BUF 63

¹⁾ Threaded lubrication hole M2 indexed to ISO thread M₁

²⁾ For high load application, please contact SKF

³⁾ For high load application, use FLRBU type. Please refer to roller screws catalogue for end shaft and support bearings definitions

Dedicated flanges for SX/BX nuts



SX nut with round flange (FHFRF)

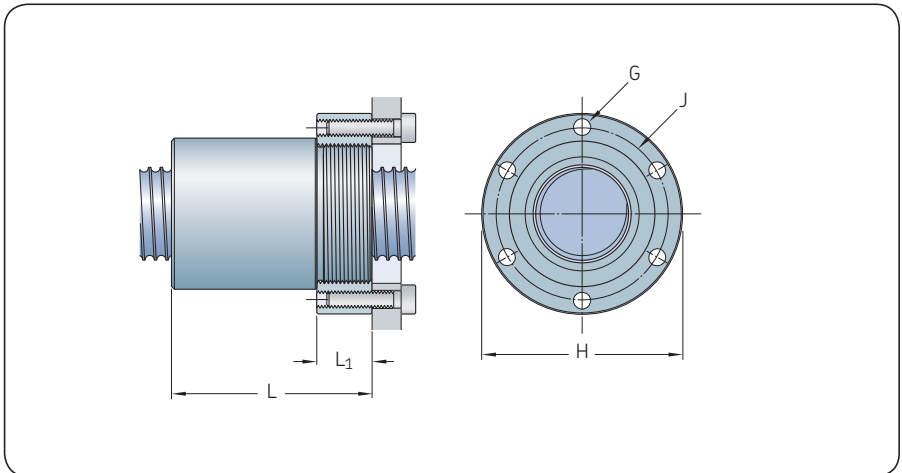

SX nut with square flange (FHFSF)

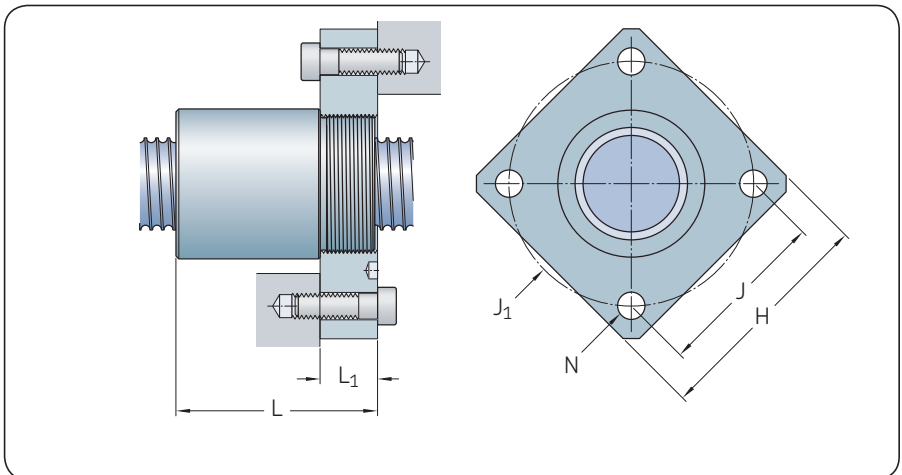

SX nut with trunnions flange (FHTF)

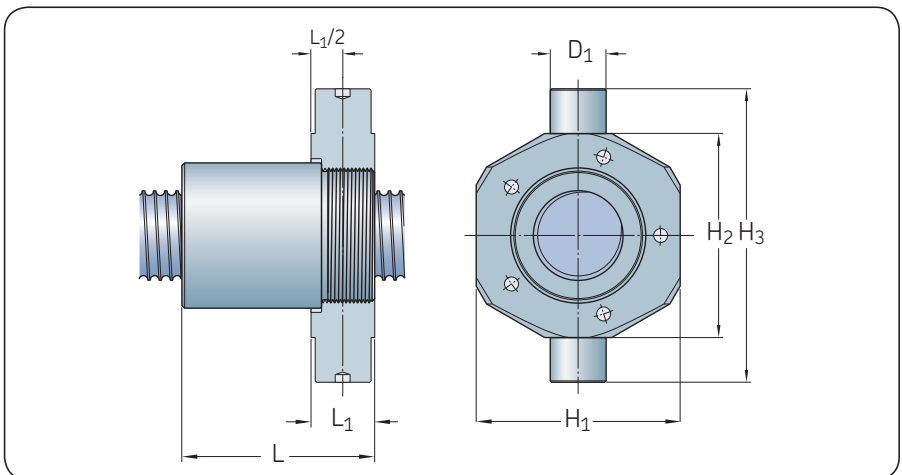

Nominal diameter d_0	Lead P_h	Dimensions					Designation
		L	L_1 h14	G	H h12	J js12	
mm	mm	mm					–
20	5	55	15	M5	52	44	FHRF 20
25	5	70	20	M6	60	50	FHRF 25
	10	85	20	M6	60	50	FHRF 25
32	5	65	20	M6	69	59	FHRF 32
	10	96	20	M6	69	59	FHRF 32
40	5	66	20	M8	82	69	FHRF 40×5
	10	106	25	M10	92	76	FHRF 40×10
	40	122	25	M10	92	76	FHRF 40×10
50	10	136	30	M12	110	91	FHRF 50
63	10	136	30	M12	125	106	FHRF 63

Nominal diameter d_0	Lead P_h	Dimensions					Designation	
		L	L_1 h14	H h14	J js12	J_1		N
mm	mm	mm					–	
20	5	55	15	60	45	63,6	6,6	FHSF 20
25	5	70	20	70	52	73,5	9	FHSF 25
	10	85	20	70	52	73,5	9	FHSF 25
32	5	65	20	80	60	84,8	9	FHSF 32
	10	96	20	80	60	84,8	9	FHSF 32
40	5	66	20	90	70	99	11	FHSF 40×5
	10	106	25	100	78	110,3	13	FHSF 40×10
	40	122	25	100	78	110,3	13	FHSF 40×10
50	10	136	30	120	94	133	15	FHSF 50
63	10	136	30	130	104	147	15	FHSF 63

Nominal diameter d_0	Lead P_h	Dimensions					Designation	Glycodur designation GLY PG	
		L	L_1	H_1 js16	H_2 h12	H_3 h12			D_1 h8
mm	mm	mm					–		
20	5	57	17	55	56	80	15	FHTF 20	151710A
25	5	71	21	60	65	97	18	FHTF 25	182015A
	10	86	21	60	65	97	18	FHTF 25	182015A
32	5	68	23	73	73	105	20	FHTF 32	202315A
	10	99	23	73	73	105	20	FHTF 32	202315A
40	5	69	23	85	85	117	20	FHTF 40×5	202315A
	10	108,5	27,5	98	98	140	25	FHTF 40×10	252820A
	40	124,5	27,5	98	98	140	25	FHTF 40×10	252820A
50	10	139	33	120	120	162	30	FHTF 50	303420A
63	10	139	33	135	135	177	30	FHTF 63	303420A



SND/BND precision screws, DIN standard 69051

Rolled thread ball screw with recirculation through inserts, DIN nut

Features

- Nominal diameter from 16 to 63 mm
- Lead from 5 to 10 mm
- Standard composite recirculation inserts
- Optional steel recirculation inserts
- Standard lead precision G5, G7 and G9
- Nut ground outside diameter / flange face
- Precision ground nut thread¹⁾
- Lubrication hole for grease nipple or for SKF SYSTEM 24 automatic lubrication kit
- Optional surface coating on shaft and nut
- Optional safety nuts. Please contact SKF for selection and usage of this option
- Optional wipers.

Benefits

- Compact nut / integral flange for easy assembly
- Design well suited for positioning screws. G5 lead precision of ground ball screws
- Optional steel recirculation inserts can act as a safety device for severe or vertical applications. Please contact SKF for such applications
- Backlash elimination by oversized balls on request (BND designation), over maximum length of 1 000 mm.



Standard

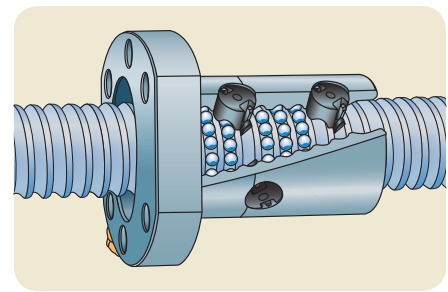

Recirculation



Assembly with flanged support bearing

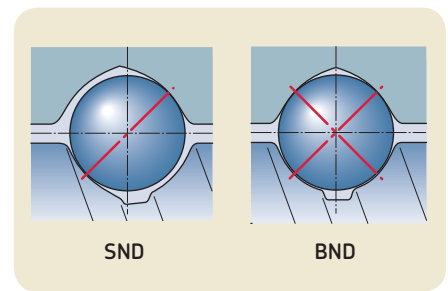

SND

BND

Nominal diameter	Lead (right hand)	Nut		Number of circuits of balls	Std play	Reduced play on request	Preload torque zero play T_{pr}	Inertia	Grease	Weight	Screw		Designation	
		Basic load ratings dynamic	static								Mass	Inertia	Grease	–
d_0	P_h	C_a	C_{oa}		mm		Nm	kgmm ²	cm ³	kg	kg/m	kgmm ² /m	cm ³ /m	–
mm	mm	kN		–	mm		Nm	kgmm ²	cm ³	kg	kg/m	kgmm ² /m	cm ³ /m	–
16	5	7,8	10,7	3	0,08	0,05	0,05	40	0,9	0,17	1,3	33	2,1	SND/BND 16×5 R
	10	10,7	17,2	2×1,8	0,07	0,03	0,06	41	1,6	0,18	1,21	30,7	2,1	SND/BND 16×10 R
20	5	11,3	17,9	3	0,1	0,05	0,08	86	1,1	0,24	2	85	2,7	SND/BND 20×5 R
	10	24,1	39	4	0,12	0,08	0,23	144	4,5	0,38	3,2	255	3,2	SND/BND 25×10 R
25	5	12,7	22,7	3	0,1	0,05	0,11	117	1,6	0,29	3,3	224	3,4	SND/BND 25×5 R
	10	24,1	39	4	0,12	0,08	0,23	144	4,5	0,38	3,2	255	3,2	SND/BND 25×10 R
32	5	19	41,3	4	0,1	0,05	0,21	364	2,1	0,54	5,6	641	4,5	SND/BND 32×5 R
	10	21,9	39	3	0,12	0,08	0,25	384	4,6	0,58	5,6	639	4,2	SND/BND 32×10 R
40	5	25,6	65,6	5	0,1	0,05	0,36	855	3,1	0,92	9	1 639	5,6	SND/BND 40×5 R/L
	10	63,3	124,1	5	0,12	0,08	0,64	1 010	10,7	1,3	8,4	1 437	5,1	SND/BND 40×10 R
50	10	71,3	157,3	5	0,12	0,08	0,88	2 130	13,1	1,8	13,6	3 736	6,5	SND/BND 50×10 R
63	10	81,5	206,9	5	0,12	0,08	1,23	4 075	16,1	2,4	22	9 913	8,4	SND/BND 63×10 R

¹⁾ Except 16×10 R: nut thread is not ground

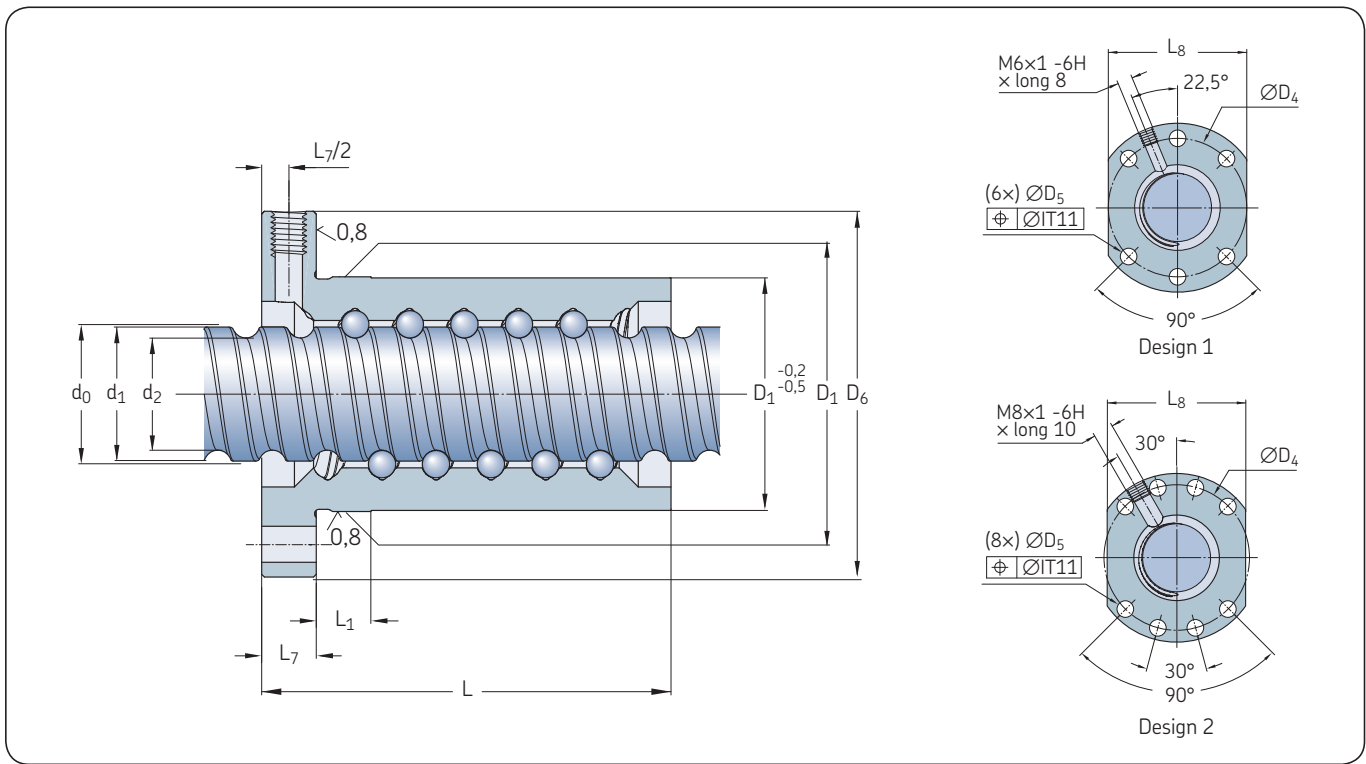

Screw	Nut		Screw							Support bearing				
$d_0 \times P_h$	D_1 g6	D_4	Design	D_5 H13	D_6 h13	L	L_1	L_7	L_8 h13	length max.	d_2	d_1	Recommended thrust support bearings	Recommended support pillow block
mm	mm	-	-	mm	mm	mm	mm	mm	mm	mm	mm	mm	-	-
16x5	28	38	1	5,5	48	43,5	10	10	40	2 000	12,7	15,2	FLBU 16/PLBU 16	BUF 16
16x10	28	38	1	5,5	48	47	37	10	40	2 000	12,6	15,2	FLBU 16/PLBU 16	BUF 16
20x5	36	47	1	6,6	58	44,5	10	10	44	4 700	16,7	19,4	PLBU 20/FLBU 20	BUF 20
25x5	40	51	1	6,6	62	44,5	10	10	48	4 700	21,7	24,6	PLBU 25/FLBU 25	BUF 25
25x10	40	51	1	6,6	62	75	10	10	48	4 700	20,5	24,6	PLBU 25/FLBU 25	BUF 25
32x5	50	65	1	9	80	51,5	10	12	62	5 700	28,7	31,6	PLBU 32/FLBU 32	BUF 32
32x10	50	65	1	9	80	64	10	12	62	5 700	27,8	32	PLBU 32/FLBU 32	BUF 32
40x5	63	78	2	9	93	58,5	10	14	70	5 700	36,7	39,6	PLBU 40/FLBU 40	BUF 40
40x10	63	78	2	9	93	91	20	14	70	5 700	34	39,4	PLBU 40/FLBU 40/FLRBU 4²⁾	BUF 40
50x10	75	93	2	11	110	93	10	16	85	5 700	44	49,7	PLBU 50/FLBU 50/FLRBU 5²⁾	BUF 50
63x10	90	108	2	11	125	95	10	18	95	5 700	57	62,8	PLBU 63/FLBU 63	BUF 63

²⁾ For high load application, use FLRBU type. Please refer to roller screws catalogue for end shaft and support bearings definitions

PND preloaded screws, DIN standard 69051

Rolled thread ball screw with recirculation through inserts, DIN nut

Features

- Nominal diameter from 16 to 63 mm
- Lead from 5 to 10 mm
- Standard composite recirculation inserts
- Optional steel recirculation inserts
- Standard lead precision G5, G7 and G9
- Nut ground outside diameter / flange face
- Precision ground nut thread¹⁾
- Standard preload 7% to 8,5% of ball screw C_a value, depending on ball screw size
- Lubrication hole for grease nipple or for SKF SYSTEM 24 automatic lubrication kit
- Optional surface coating on shaft and nut
- Optional safety nuts. Please contact SKF for selection and usage of this option
- Optional wipers.

Benefits

- Compact nut / integral flange for easy assembly
- One-piece nut¹⁾ with internal preload for compactness and optimum rigidity
- Design well suited for positioning screws. G5 lead precision of ground ball screws
- Optional steel recirculation inserts can act as a safety device for severe or vertical applications. Please contact SKF for such applications.

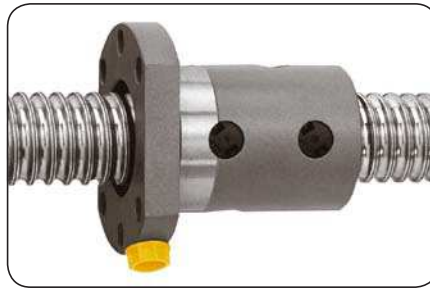

Standard

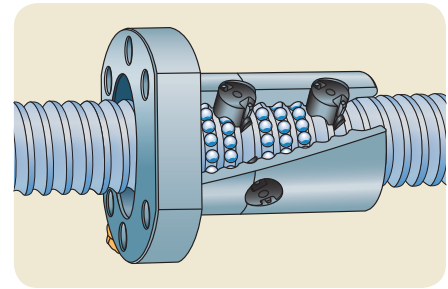

Recirculation

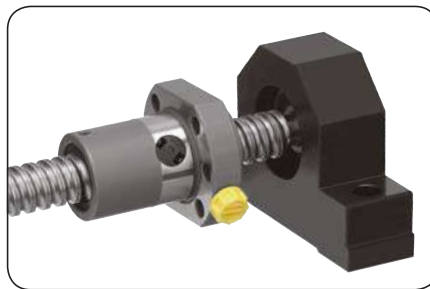

Assembly with pillow block

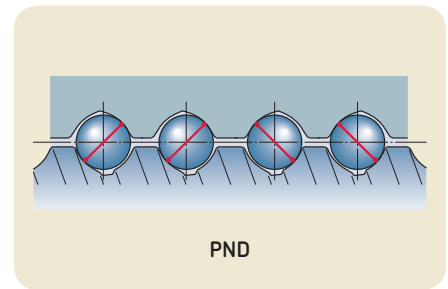

PND

Nominal diameter	Lead (right hand)	Nut		Number of circuits of balls	Preload torque average T_{pr}	Stiffness R_n	Inertia	Grease	Weight	Screw			Designation
		Basic load ratings dynamic C_a	static C_{oa}							Mass	Inertia	Grease	
d_0	P_h									kg/m	kgmm ² /m	cm ³ /m	
mm	mm	kN		–	Nm	N/μm	kgmm ²	cm ³	kg				–
16	5	5,5	7,1	2×2	0,08	147	46	1	0,19	1,3	33	2,1	PND 16×5 R PND 16×10 R ¹⁾
	10	10,7	17,2	2×2×1,8	0,15	263	56	2,7	0,28	1,21	30,7	1,9	
20	5	8	11,9	2×2	0,14	248	91	1,3	0,26	2	85	2,7	PND 20×5 R
	10	12,7	22,7	2×3	0,28	436	405	2	0,4	3,3	224	3,4	PND 25×5 R PND 25×10 R
25	5	13,3	19,5	2×2	0,3	264	245	4,5	0,53	3,2	255	3,2	
	10	19	41,3	2×4	0,52	734	453	3,2	0,715	5,6	641	3,2	PND 32×5 R PND 32×10 R
32	5	21,9	39	2×3	0,61	490	490	7,6	0,81	5,6	639	4,1	
	10	25,6	65,6	2×5	0,71	968	1 110	4,8	1,3	9	1 639	5,5	PND 40×5 R/L PND 40×10 R
40	5	52,2	99,3	2×4	1,47	793	1 290	15,5	1,8	8,4	1 437	4,9	
	10	71,3	157,3	2×5	2,47	1 222	2 940	27,5	2,6	13,6	3 736	7,9	PND 50×10 R
50	10	81,5	206,9	2×5	3,46	1 448	5 290	26,8	3,2	22	9 913	7,9	PND 63×10 R

¹⁾ Except 16×10 R: nut thread is not ground, double nut design

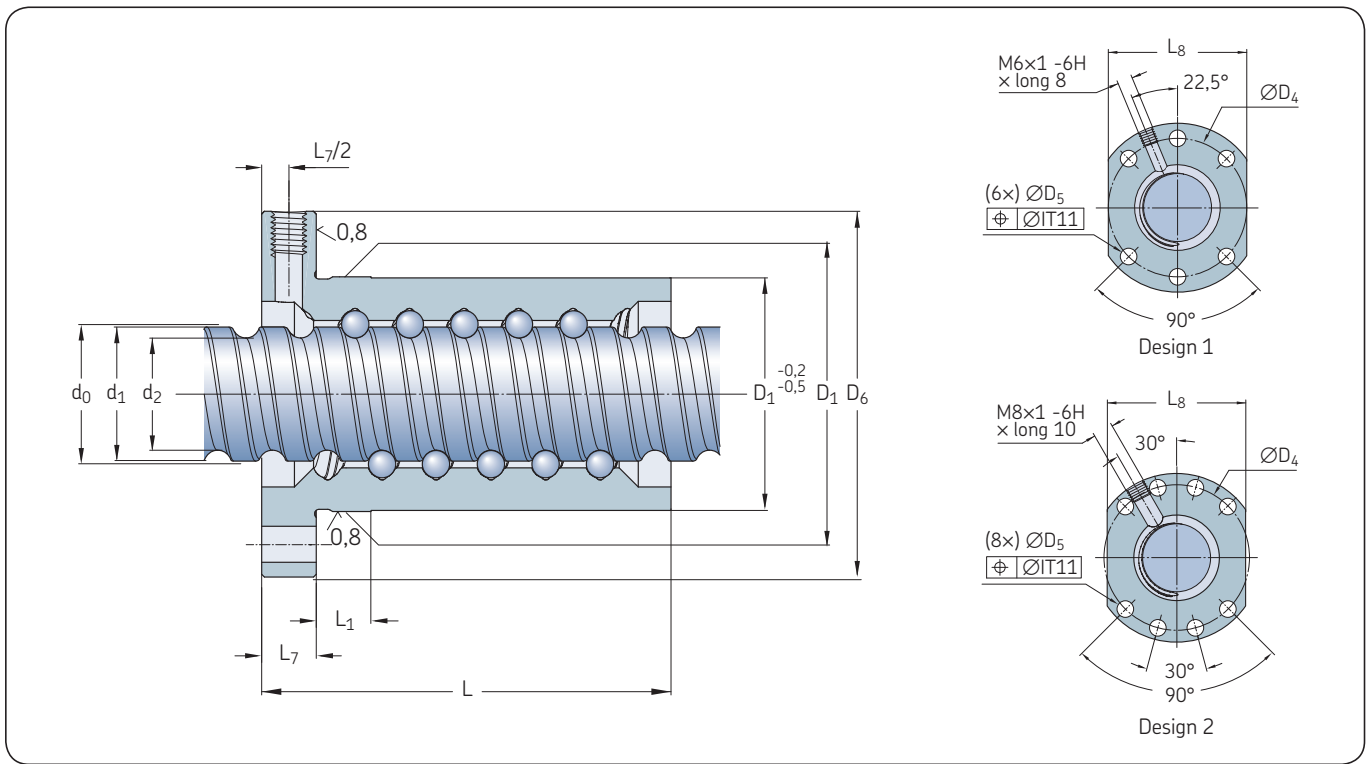

Screw	Nut									Screw			Support bearing	Recommended thrust support bearings	Recommended pillow block
$d_0 \times P_h$	D_1	D_4	Design	D_5	D_6	L	L_1	L_7	L_8	length max.	d_2	d_1			
mm	mm			H13	h13				h13	mm					
16x5	28	38	1	5,5	48	48	10	10	40	2 000	12,7	15,2	FLBU 16/PLBU 16	BUF 16	
16x10	28	38	1	5,5	48	87	77	10	40	2 000	12,6	15,2	FLBU 16/PLBU 16	BUF 16	
20x5	36	47	1	6,6	58	50	10	10	44	4 700	16,7	19,4	PLBU 20/FLBU 20	BUF 20	
25x5	40	51	1	6,6	62	62	10	10	48	4 700	21,7	24,6	PLBU 25/FLBU 25	BUF 25	
25x10	40	51	1	6,6	62	75	10	10	48	4 700	20,5	24,6	PLBU 25/FLBU 25	BUF 25	
32x5	50	65	1	9	80	74	10	12	62	5 700	28,7	31,6	PLBU 32/FLBU 32	BUF 32	
32x10	50	65	1	9	80	100	10	12	62	5 700	27,8	32	PLBU 32/FLBU 32	BUF 32	
40x5	63	78	2	9	93	88	10	14	70	5 700	36,7	39,6	PLBU 40/FLBU 40	BUF 40	
40x10	63	78	2	9	93	130	20	14	70	5 700	34	39,4	PLBU 40/FLBU 40/FLRBU 4²⁾	BUF 40	
50x10	75	93	2	11	110	151	10	16	85	5 700	44	49,7	PLBU 50/FLBU 50/FLRBU 5²⁾	BUF 50	
63x10	90	108	2	11	125	153	10	18	95	5 700	57	62,8	PLBU 63/FLBU 63	BUF 63	

²⁾ For high load application, use FLRBU type. Please refer to roller screws catalogue for end shaft and support bearings definitions

SN/BN precision screws

Rolled thread ball screw with recirculation through inserts, cylindrical flange

Features

- Nominal diameter from 16 to 63 mm
- Lead from 5 to 10 mm
- Standard composite recirculation inserts
- Optional steel recirculation inserts
- Standard lead precision G5, G7 and G9
- Nut ground outside diameter / flange face
- Precision ground nut thread
- Lubrication hole for grease nipple or for SKF SYSTEM 24 automatic lubrication kit
- Optional surface coating on shaft and nut
- Optional safety nuts. Please contact SKF for selection and usage of this option
- Optional wipers.

Benefits

- Economical compact nut / integral flange for easy assembly
- Design well suited for positioning screws. G5 lead precision of ground ball screws
- Optional steel recirculation inserts can act as a safety device for severe or vertical applications. Please contact SKF for such applications
- Backlash elimination by oversized balls on request (BN designation), over maximum length of 1 000 mm.



Standard

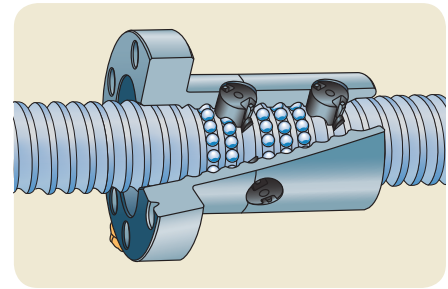

Recirculation



Customised

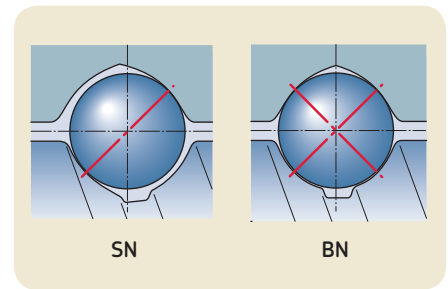

SN

BN

Nominal diameter	Lead (right hand)	Nut		Number of circuits of balls	Std play	Reduced play on request	Preload torque zero play T_{pr}	Inertia	Grease	Weight	Screw			Designation
		Basic load ratings dynamic	static								Mass	Inertia	Grease	
d_0	P_h	C_a	C_{oa}		mm		Nm	kgmm ²	cm ³	kg	kg/m	kgmm ² /m	cm ³ /m	–
mm	mm	kN	–	–	mm		Nm	kgmm ²	cm ³	kg	kg/m	kgmm ² /m	cm ³ /m	–
16	5	7,8	10,7	3	0,08	0,05	0,05	45	0,9	0,18	1,3	33	2,1	SN/BN 16×5 R
20	5	11,3	17,9	3	0,1	0,05	0,08	88	1,2	0,24	2	85	2,7	SN/BN 20×5 R
25	5	12,7	22,7	3	0,1	0,05	0,11	127	1,6	0,28	3,3	224	3,4	SN/BN 25×5 R
	10	24,1	39	4	0,12	0,08	0,23	244	4,5	0,53	3,2	255	3,2	SN/BN 25×10 R
32	5	19	41,3	4	0,1	0,05	0,21	250	2,1	0,4	5,6	641	4,5	SN/BN 32×5 R
	10	21,9	39	3	0,12	0,08	0,25	673	4,6	0,83	5,6	639	4,2	SN/BN 32×10 R
40	5	25,6	65,6	5	0,1	0,05	0,36	495	3,1	0,58	9	1 639	5,6	SN/BN 40×5 R/L
	10	63,3	124,1	5	0,12	0,08	0,64	1 285	10,7	1,4	8,4	1437	5,1	SN/BN 40×10 R
50	10	71,3	157,3	5	0,12	0,08	0,88	1 305	13,1	1,8	13,6	3 736	6,5	SN/BN 50×10 R
63	10	81,5	206,9	5	0,12	0,08	1,23	4 180	16,1	2,25	22	9 913	8,4	SN/BN 63×10 R

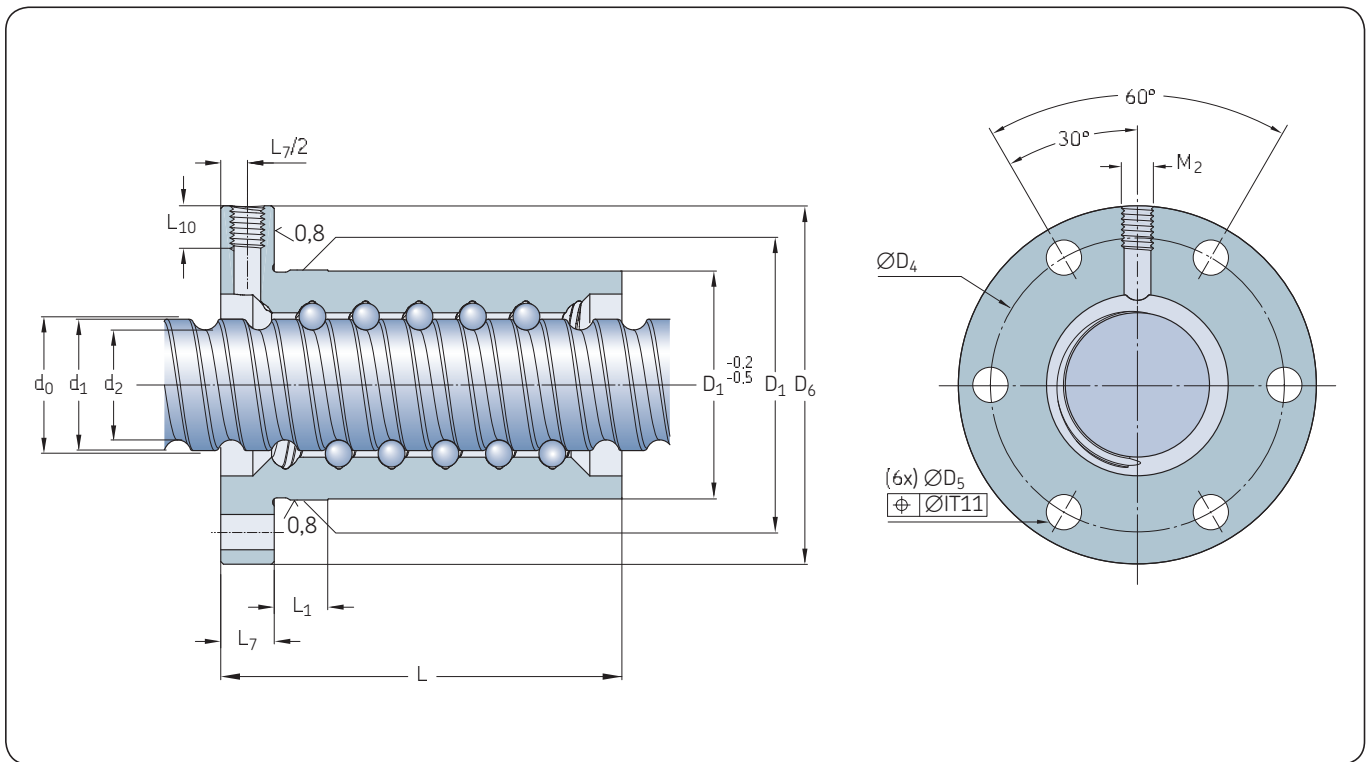

Screw	Nut									Screw	Support bearing Recommended thrust support bearings		Recommended support pillow block	
$d_0 \times P_h$	D_1 g6	D_4	D_5 H13	D_6 h13	L	L_1	L_7	L_{10}	M_2 6H	length max.	d_2	d_1		
mm	mm									mm	mm		-	
16x5	28	38	6x5.5	48	43,5	10	10	8	M6	2000	12,7	15,2	FLBU 16 / PLBU 16	BUF 16
20x5	33	45	6x6.6	57	44,5	10	10	8	M6	4700	16,7	19,4	PLBU 20 / FLBU 20	BUF 20
25x5	38	50	6x6.6	62	44,5	10	10	8	M6	4700	21,7	24,6	PLBU 25 / FLBU 25	BUF 25
25x10	43	55	6x6.6	67	75	10	10	8	M6	4700	20,5	24,6	PLBU 25 / FLBU 25	BUF 25
32x5	45	58	6x6.6	70	51,5	10	12	8	M6	5700	28,7	31,6	PLBU 32 / FLBU 32	BUF 32
32x10	54	70	6x9	87	64	10	12	10	M8x1	5700	27,8	32	PLBU 32 / FLBU 32	BUF 32
40x5	53	68	6x6.6	80	58,5	10	14	8	M6	5700	36,7	39,6	PLBU 40 / FLBU 40	BUF 40
40x10	63	78	6x9	95	91	20	14	10	M8x1	5700	34	39,4	PLBU 40 / FLBU 40 / FLRBU 4 ¹⁾	BUF 40
50x10	72	90	6x11	110	99	10	16	10	M8x1	5700	44	49,7	PLBU 50 / FLBU 50 / FLRBU 5 ¹⁾	BUF 50
63x10	85	105	6x11	125	101	10	18	10	M8x1	5700	57	62,8	PLBU 63 / FLBU 63	BUF 63

¹⁾ For high load application, use FLRBU type. Please refer to roller screws catalogue for end shaft and support bearings definitions

PN preloaded screws

Rolled thread ball screw with recirculation through inserts, cylindrical flange

Features

- Nominal diameter from 16 to 63 mm
- Lead from 5 to 10 mm
- Standard composite recirculation inserts
- Optional steel recirculation inserts
- Standard lead precision G5, G7 and G9
- Nut ground outside diameter / flange face
- Precision ground nut thread
- Standard preload 7% to 8,5% of ball screw C_a value, depending on ball screw size
- Lubrication hole for grease nipple or for SKF SYSTEM 24 automatic lubrication kit
- Optional surface coating on shaft and nut
- Optional safety nuts. Please contact SKF for selection and usage of this option
- Optional wipers.

Benefits

- Economical compact nut / integral flange for easy assembly
- One-piece nut with internal preload for compactness and optimum rigidity
- Design well suited for positioning screws. G5 lead precision of ground ball screws
- Optional steel recirculation inserts can act as a safety device for severe or vertical applications. Please contact SKF for such applications.



Standard

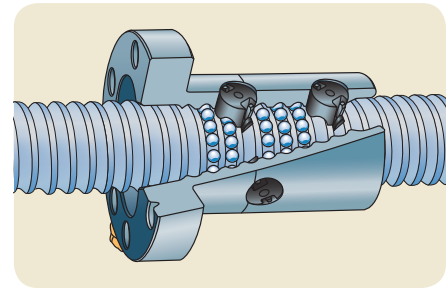

Recirculation



Customised

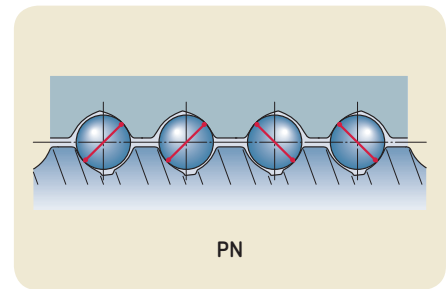

Nominal diameter	Lead (right hand)	Nut		Number of circuits of balls	Preload torque average T_{pr}	Stiffness R_n	Inertia	Grease	Weight	Screw		Designation	
		Basic load ratings dynamic C_a	static C_{oa}							Mass	Inertia		Grease
d_0	P_h	C_a	C_{oa}		T_{pr}	R_n				kg/m	kgmm ² /m	cm ³ /m	–
mm	mm	kN		–	Nm	N/μm	kgmm ²	cm ³	kg				
16	5	5,5	7,1	2×2	0,08	147	46	1	0,19	1,3	33	2,1	PN 16×5 R
20	5	8	11,9	2×2	0,14	248	91	1,1	0,26	2	85	2,4	PN 20×5 R
25	5	17,7	22,7	2×3	0,28	436	400	2,1	0,39	3,3	224	3,4	PN 25×5 R
	10	13,3	19,5	2×2	0,3	264	245	4,1	0,53	3,2	255	2,8	PN 25×10 R
32	5	19	41,3	2×4	0,52	734	390	3,2	0,5	5,6	641	4,4	PN 32×5 R
	10	21,9	39	2×3	0,61	490	830	7,6	1,13	5,6	639	4,1	PN 32×10 R
40	5	25,6	65,6	2×5	0,71	968	585	4,8	0,74	9	1 639	5,5	PN 40×5 R/L
	10	52,2	99,3	2×4	1,47	793	1 530	14,6	1,8	8,4	1 437	4,9	PN 40×10 R
50	10	71,3	157,3	2×5	2,47	1 222	2 930	27,5	2,6	13,6	3 736	7,9	PN 50×10 R
63	10	81,5	206,9	2×5	3,46	1 448	5 980	26,8	3,2	22	9 913	7,9	PN 63×10 R

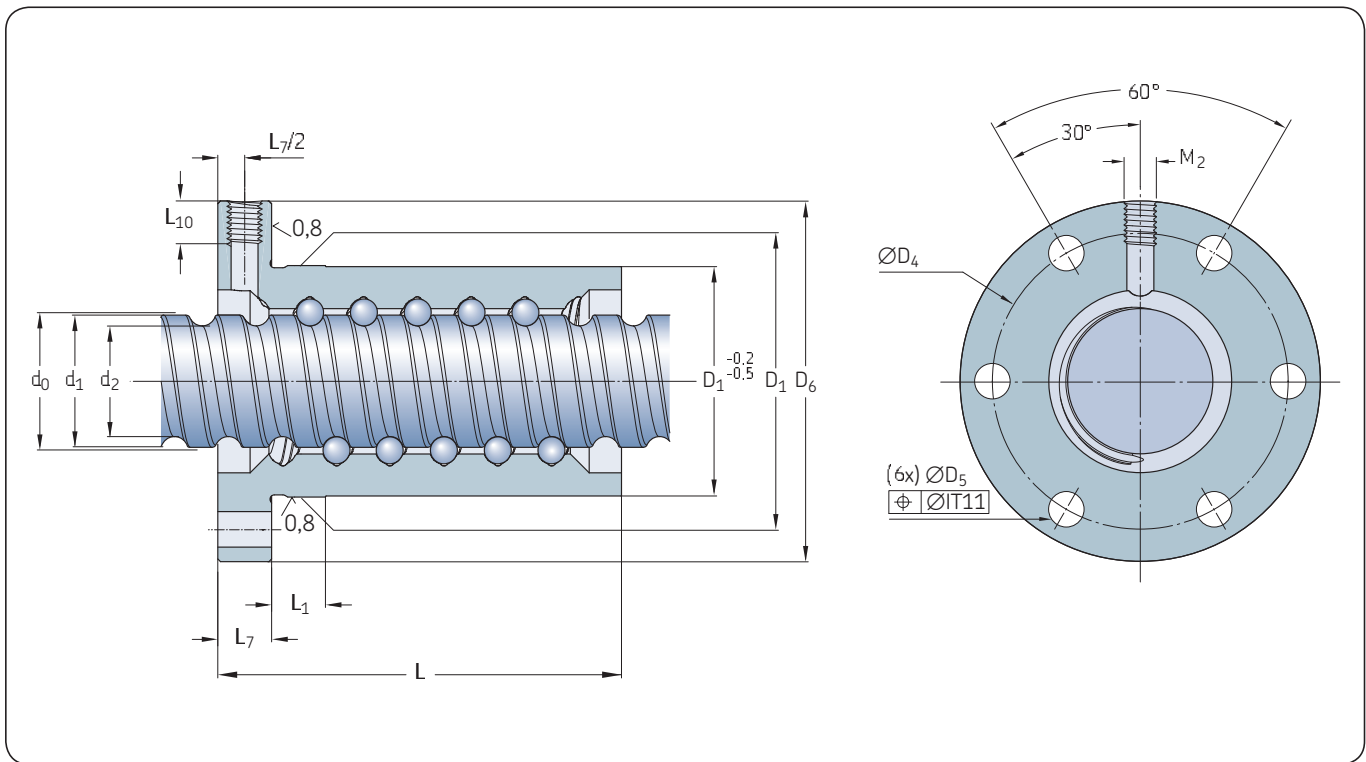

Screw $d_0 \times P_h$ mm	Nut									Screw length max. mm	d_2 mm	d_1 mm	Support bearing Recommended thrust support bearings	Recommended support pillow block
	D_1 g6 mm	D_4 js12 mm	D_5 H13 mm	D_6 h13 mm	L	L_1	L_7	L_{10}	M_2 6H					
16x5	28	38	6x5,5	48	48	10	10	8	M6	2 000	12,7	15,2	FLBU 16/PLBU 16	BUF 16
20x5	33	45	6x6,6	57	50	10	10	8	M6	4 700	16,7	19,4	PLBU 20/FLBU 20	BUF 20
25x5	38	50	6x6,6	62	62	10	10	8	M6	4 700	21,7	24,6	PLBU 25/FLBU 25	BUF 25
25x10	43	55	6x6,6	67	75	10	10	8	M6	4 700	20,5	24,6	PLBU 25/FLBU 25	BUF 25
32x5	45	58	6x6,6	70	74	10	12	8	M6	5 700	28,7	31,6	PLBU 32/FLBU 32	BUF 32
32x10	54	70	6x9	87	100	10	12	10	M8x1	5 700	27,8	32	PLBU 32/FLBU 32	BUF 32
40x5	53	68	6x6,6	80	88	10	14	8	M6	5 700	36,7	39,6	PLBU 40/FLBU 40	BUF 40
40x10	63	78	6x9	95	126	20	14	10	M8x1	5 700	34	39,4	PLBU 40/FLBU 40/FLRBU 4 ¹⁾	BUF 40
50x10	72	90	6x11	110	151	10	16	10	M8x1	5 700	44	49,7	PLBU 50/FLBU 50/FLRBU 5 ¹⁾	BUF 50
63x10	85	105	6x11	125	153	10	18	10	M8x1	5 700	57	62,8	PLBU 63/FLBU 63	BUF 63

¹⁾ For high load application, use FLRBU type. Please refer to roller screws catalogue for end shaft and support bearings definitions

SL/TL long lead screws

Rolled thread ball screw for high linear speed

Features

- Nominal diameter from 25 to 50 mm
- Lead from 20 to 50 mm
- Lubrication hole for grease nipple or for SKF SYSTEM 24 automatic lubrication kit
- Standard protection at each end of the nut with composite wipers integrated into recirculation caps (NOWPR)
- Optional double protection at each end of the nut with additional brush wipers fitted into recirculation caps (WPR)
- Optional surface coating on shaft and nut
- Optional safety nuts. Please contact SKF for selection and usage of this option.



Standard

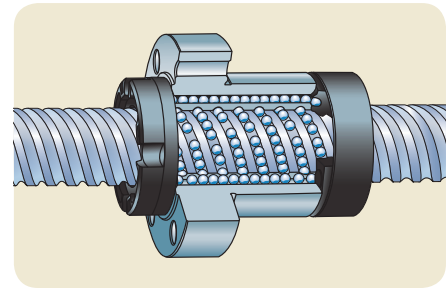

Recirculation

Benefits

- High rotational speed up to $nd_0 = 90\,000$, resulting in high linear speed up to 110 m/min
- Nut design well suited for transport and positioning screw applications requiring high velocity such as woodworking, some functions in plastic injection presses, pick-&-place, etc.
- Backlash elimination (TL designation).



Customised

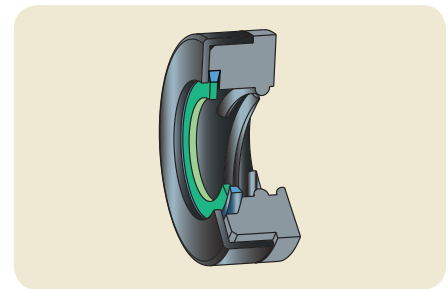

Optional double protection

Nominal diameter	Lead (right hand)	Nut				TL (with backlash elimination)				Screw			Designation		
		SL (with play) Basic load ratings dynamic static	Std play	TL (with backlash elimination) Basic load ratings dynamic static	Preload torque zero play T_{pr}	Number of circuits of balls	Inertia	Grease	Weight	Mass	Inertia	Grease			
d_0	P_h	C_a	C_{oa}	mm	C_a	C_{oa}	Nm	–	kgmm ²	cm ³	kg	kg/m	kgmm ² /m	cm ³ /m	–
mm	mm	kN		mm	kN										
25	20	22,8	51,5	0,08	12,6	25,8	0,04-0,36	4×1,7	480	3	0,57	3,3	215	3,4	SL/TL 25×20 R
	25	22,3	50,6	0,08	12,3	25,3	0,04-0,36	4×1,7	400	3,6	0,66	3,2	210	3,3	SL/TL 25×25 R
32	20	25,4	65,2	0,08	14	32,6	0,05-0,45	4×1,7	550	3,4	0,7	5,1	530	4,4	SL/TL 32×20 R
	32	26,1	69,3	0,08	14,4	34,7	0,05-0,50	4×1,8	450	4,5	0,7	5,4	600	4,3	SL/TL 32×32 R
	32	26,1	69,3	0,08	14,4	34,7	0,05-0,50	4×1,8	450	4,5	0,7	5,4	600	4,3	SLD/TLD 32×32 R
	40	12,6	29,8	0,08	6,9	14,9	0,05-0,50	4×0,8	515	3	0,65	4,9	490	4,4	SL/TL 32×40 R
40	20	41,3	128,8	0,08	22,8	64,4	0,05-0,55	4×2,7	1 420	6,6	1,2	8,2	1 380	5,5	SL/TL 40×20 R
	40	51,7	130,5	0,1	28,5	65,3	0,05-0,55	4×1,7	3 300	12,5	2,4	8,1	1 330	5,2	SL/TL 40×40 R
50	50	92,9	235,1	0,12	51,2	117,6	0,1-0,9	4×1,7	6 060	19,4	3,3	13,2	3 560	6,4	SL/TL 50×50 R

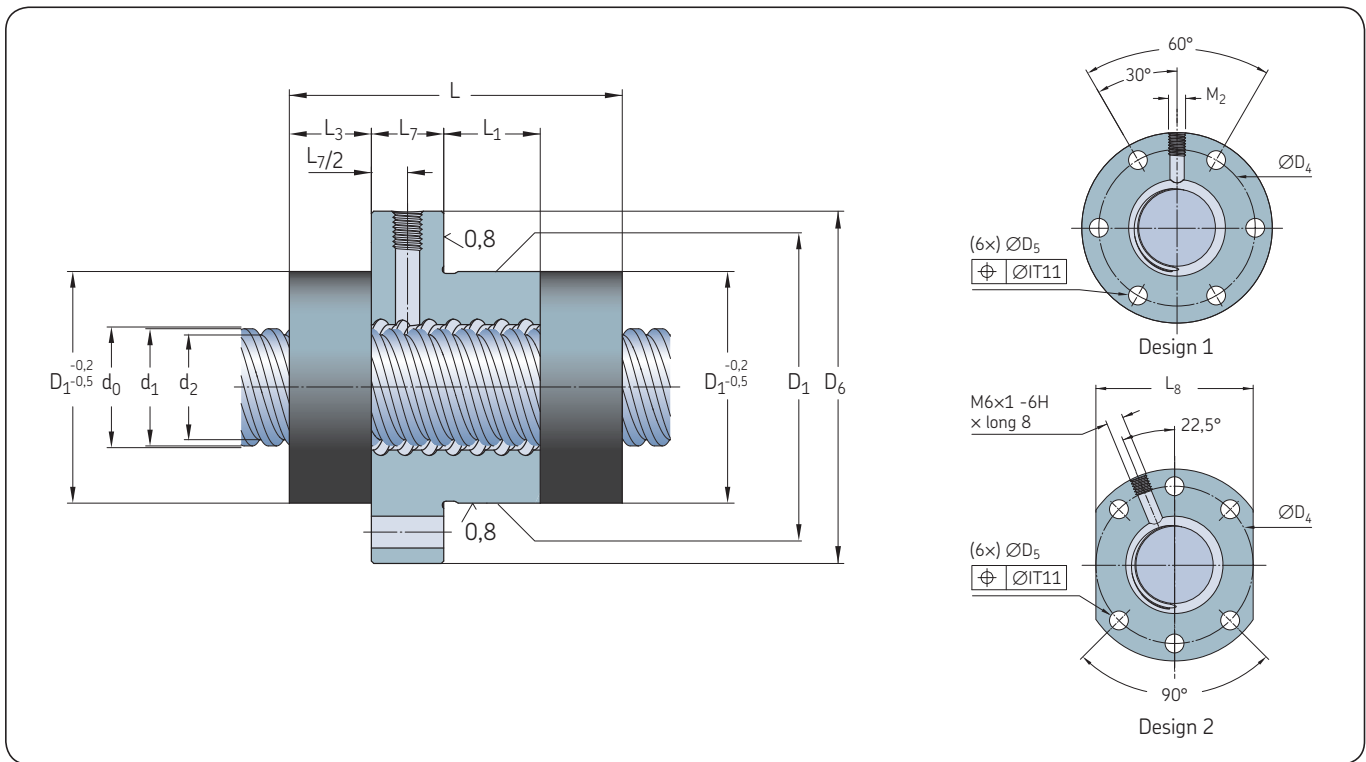

Screw	Nut													Screw			Support bearing Recommended thrust support bearings	Recommended support pillow block
$d_0 \times P_h$	D_1 g9	D_4 js12	Design	D_5 H13	D_6	L	L_1	L_3	L_7	L_8 h13	L_{10}	M_2	length max.	d_2	d_1			
mm	mm	-		mm									mm			-		
25x20	48	60	1	6x6,6	73	66,8	18	17,6	15	N/A	8	M6	4 700	21,7	24,3	PLBU 25/FLBU 25	BUF 25	
25x25	48	60	1	6x6,6	73	78,2	27	18,7	15	N/A	8	M6	4 700	21,5	24,4	PLBU 25/FLBU 25	BUF 25	
32x20	56	68	1	6x6,6	80	67,4	18	17,9	15	N/A	8	M6	5 700	27,5	30	PLBU 32/FLBU 32/FLRBU3 ¹⁾	BUF 32	
32x32	56	68	1	6x6,6	80	80,3	41	13	15	N/A	8	M6	5 700	28,4	31,1	PLBU 32/FLBU 32/FLRBU3 ¹⁾	BUF 32	
32x32	50 g6	65	2	6x9	80	80,3	41	13	15	62	8	M6	5 700	28,4	31,1	PLBU 32/FLBU 32/FLRBU3 ¹⁾	BUF 32	
32x40	53 g6	68	1	6x6,6	80	54,8	17	12,2	15	N/A	8	M6	5 700	26,9	29,6	PLBU 32/FLBU 32	BUF 32	
40x20	63	78	1	6x9	95	87,3	38	18	15	N/A	8	M6	5 700	35,2	37,7	PLBU 40/FLBU 40	BUF 40	
40x40	72	90	1	6x11	110	110,8	44	21,6	25	N/A	10	M8x1	5 700	34,2	38,3	PLBU 40/FLBU 40/FLRBU 4 ¹⁾	BUF 40	
50x50	85	105	1	6x11	125	134	60	25,5	25	N/A	10	M8x1	5 700	43,5	49,1	PLBU 50/FLBU 50/FLRBU 5 ¹⁾	BUF 50	

¹⁾ For high load application, use FLRBU type. Please refer to roller screws catalogue for end shaft and support bearings definitions

SLT/TLT rotating nut

Long lead rolled ball screw with rotating nut

Concept

The main purpose of this solution is to minimize the inertia phenomenon associated with long rotating shafts.

The long lead screw shaft is rigidly fixed to the machine frame. The ball nut, rotating inside a bearing housing and driven via a tension belt, moves along the screw shaft.

The customers are responsible for the sourcing and assembly of the electric motor, belt, pulleys and frame holding the bearing housing.

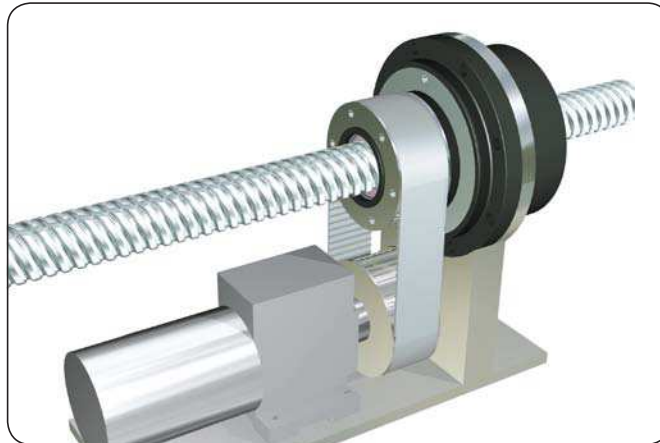

Features

- Nominal diameter from 25 to 50 mm
- Lead from 20 to 50 mm
- 72 series angular contact bearings are directly mounted on the nut outer diameter
- Bearings are preloaded in back-to-back arrangement in order to fully support the moment created by the belt tension
- 2 Nilos rings protect the bearings against pollution and permit lubrication for life
- Brush wipers are mounted at each end of the nut in the standard configuration for better protection against contamination
- The ball screw assembly is lubricated through a nipple mounted on the housing external diameter in the standard version
- Standard grease is SKF LGMT2. Other lubricants are available on request.

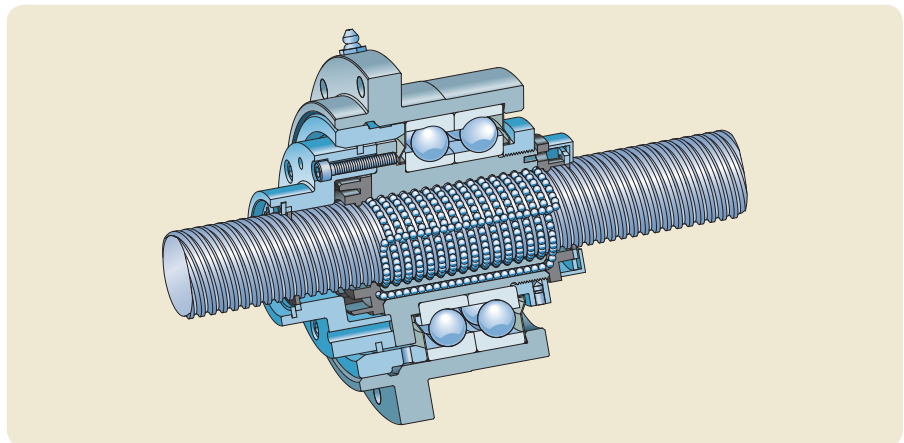

Nominal diameter	Lead (right hand)	Ball screw capacities				Bearing		Rotating nut			Designation	
		SL Basic load ratings	TL Basic load ratings	SL Basic load ratings	TL Basic load ratings	Basic load ratings	Basic load ratings	Max trans- missible torque	Max trans- missible axial load	Inertia with pulley support		Mass
d_0	P_h	C_a	C_{oa}	C_a	C_{oa}	C_a	C_{oa}					
mm	mm	kN				kN		Nm	kN	kgmm ²	kg	–
25	20	39,2	97,0	21,6	48,5	61,8	56	180	68,3	1 012	4,5	SLT/TLT 25×20 R
	25	33,2	80,4	18,3	40,2	61,8	56	180	68,3	1 023	4,6	SLT/TLT 25×25 R
32	20	49,6	141,8	27,3	70,9	78	76,5	209	107	1 935	7,2	SLT/TLT 32×20 R
	32	32,2	88,6	17,7	44,3	78	76,5	209	87,3	1 919	7,1	SLT/TLT 32×32 R
	40	25,3	67,0	13,9	33,5	78	76,5	209	81,7	1 949	7,1	SLT/TLT 32×40 R
40	20	54,2	176,5	29,8	88,3	93,6	91,5	240	116	3 095	7,5	SLT/TLT 40×20 R
	40	51,7	130,5	28,5	65,3	114	118	246	93,3	3 784	8,4	SLT/TLT 40×40 R
50	50	92,9	235,1	51,2	117,6	156	166	803	162	1 1482	15,5	SLT/TLT 50×50 R

Benefits

- High rotational speed up to $nd_0 = 90\,000$, resulting in high linear speed up to 110 m/min
- Compact, easy and simple solution to incorporate into application
- Fixed screw shaft for simplified mounting into application
- Inertia is considerably reduced, for example: 3 800 kgmm² instead of 6 000 kgmm² for a screw shaft 40×40 with 4,5 m stroke
- Lower motor power requirements resulting from lower system inertia
- Backlash elimination (TLT designation).

Screw Dimensions

$d_0 \times P_h$	L	L ₁	L ₂	L ₃	L ₄	L ₅	L ₆	L ₇	L ₈	L ₉
mm										
25×20	121,2	15	12,4	19,9	74	2,9	16,9	12,4	15	15
25×25	126,3	15	12,4	19,9	74	2,9	22	12,4	15	15
32×20	132,9	20	3,8	27,5	89	2,2	17,9	20	15	20
32×32	126,8	20	3,8	27,5	89	2,2	11,8	20	15	20
32×40	125,9	20	3,8	27,5	89	2,2	10,9	20	15	20
40×20	136,7	20	9,3	22,5	85	4,7	17,7	15	15	20
40×40	159,6	47	8,8	19	83	0	20,8	11,5	15	20
50×50	163,5	20	15,5	25,4	100	4,5	23,5	15,7	20	25

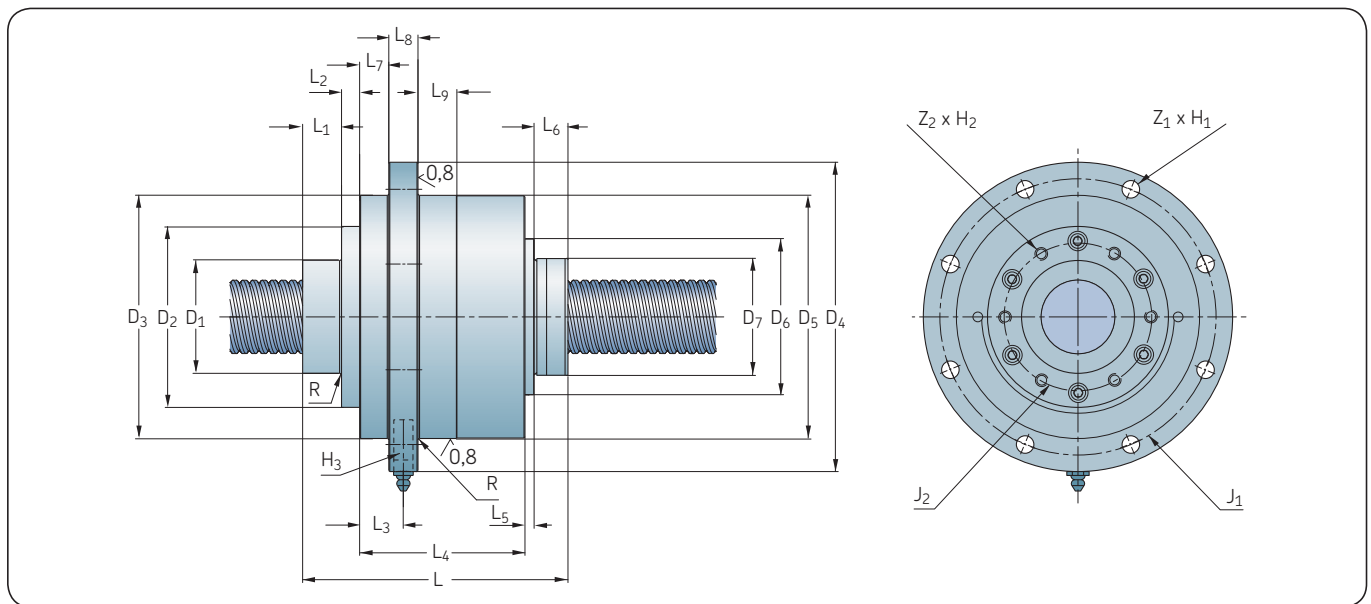

Screw Dimensions

$d_0 \times P_h$	D ₁	D ₂ h8	D ₃	D ₄	D ₅ g6	D ₆	D ₇	R max.	J ₁	J ₂	Z ₁ × H ₁	Z ₂ × H ₂ × useful depth	H ₃
mm													
25×20	40	72,5	100	133	100	65	48	0,8	116	55	6×Ø9	6×M6×20	M6×1
25×25	40	72,5	100	133	100	65	48	0,8	116	55	6×Ø9	6×M6×20	M6×1
32×20	50	82	119,5	150	120	76	56	0,8	135	68	6×Ø9	6×M6×20	M6×1
32×32	50	82	119,5	150	120	76	50	0,8	135	68	6×Ø9	6×M6×20	M6×1
32×40	50	82	119,5	150	120	76	53	0,8	135	68	6×Ø9	6×M6×20	M6×1
40×20	58	93	125	159	125	80	63	0,8	142	75	8×Ø9	6×M6×20	M8×1
40×40	60	93	137	168	137	N/A	72	1,6	153	80	8×Ø9	6×M6×20	M8×1
50×50	70	120	170	210	170	110	85	1,6	190	106	8×Ø11	6×M8×30	M8×1

All tolerances js13 if not specified.

Shaft end combinations

- In the ordering code, shaft ends machining is defined by:
 - One letter for nominal diameter $d_0 < 16$ mm
 - Two letters for nominal diameter $d_0 \geq 16$ mm, detailing the combination of two machined ends (→ designation system **page 54**)
- Machined ends are detailed for nominal diameter < 16 mm (→ **page 37**)
- Machined ends are detailed for nominal diameter ≥ 16 mm (→ **pages 38 to 41**).

S, SA and UA end machining types

*) S and SA: end is machined to thread root diameter d_2 . It is available for all screw shaft nominal diameters (→ **fig. 10**)

*) UA: end is machined to diameter d_3 under induction hardened layer. Any length can be used. UA end machining is available for ball screws with nominal diameter d_0 starting from 16 mm (→ **fig. 10**).

Diameter < 16 mm		Diameter ≥ 16 mm	
Order code	Two machined ends	Order code	Two machined ends
A (without length indication)	cut only	AA (without length indication)	cut only
A (+ length)	cut + annealed		
B	1 + 2	BA	1A + 2A
F ¹⁾	2 + 2	FA ¹⁾	2A + 2A
G ¹⁾	2 + 3	GA ¹⁾	2A + 3A
H	2 + 4	HA	2A + 4A
J	2 + 5	JA	2A + 5A
M	3 + 5	MA	3A + 5A
S ^{*)} (+ length)	end machined to root diameter d_2 , any length	SA ^{*)} (+ length)	end machined to root diameter d_2 , any length
		UA ^{*)} (+ length)	end machined to diameter d_3 under induction hardening, any length
K	keyway	K	keyway
Z	end machined according to customer drawing on request	Z	end machined according to customer drawing on request

¹⁾Attention! This mounting requires the greatest care. Please contact SKF.

Dimensions	d_2		d_3	
	mm		mm	
6x2	4,7			
8x2,5	6,3			
10x2	8,3			
10x3	7,8			
10x4	7,4			
12x2	9,9			
12x4	9,4			
12x5	9,3			
12,7x12,7	10,2			
14x4	11,9			
16x2	14,3		12	
16x5	12,7		9	
16x10	12,6		9	
20x5	16,7		14	

Dimensions	d_2		d_3	
	mm		mm	
25x5	21,7		19	
25x10	20,5		18	
25x20	21,7		19	
25x25	21,5		18	
32x5	28,7		26	
32x10	27,8		25	
32x20	27,4		24	
32x32	28,4		26	
32x40	26,9		24	
40x5	36,7		34	
40x10	34,0		31	
40x20	35,1		32	
40x40	34,2		31	
50x10	44,0		41	
50x50	43,4		40	
63x10	57,0		54	

Fig. 10

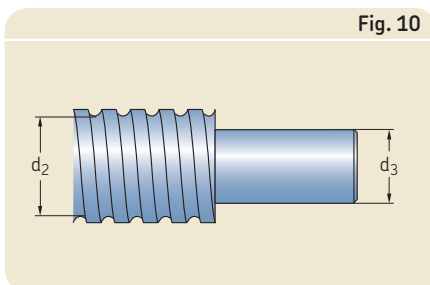

Standard end machining for nominal diameter < 16 mm

For SD/BD/SH-SDS/BDS/SHS

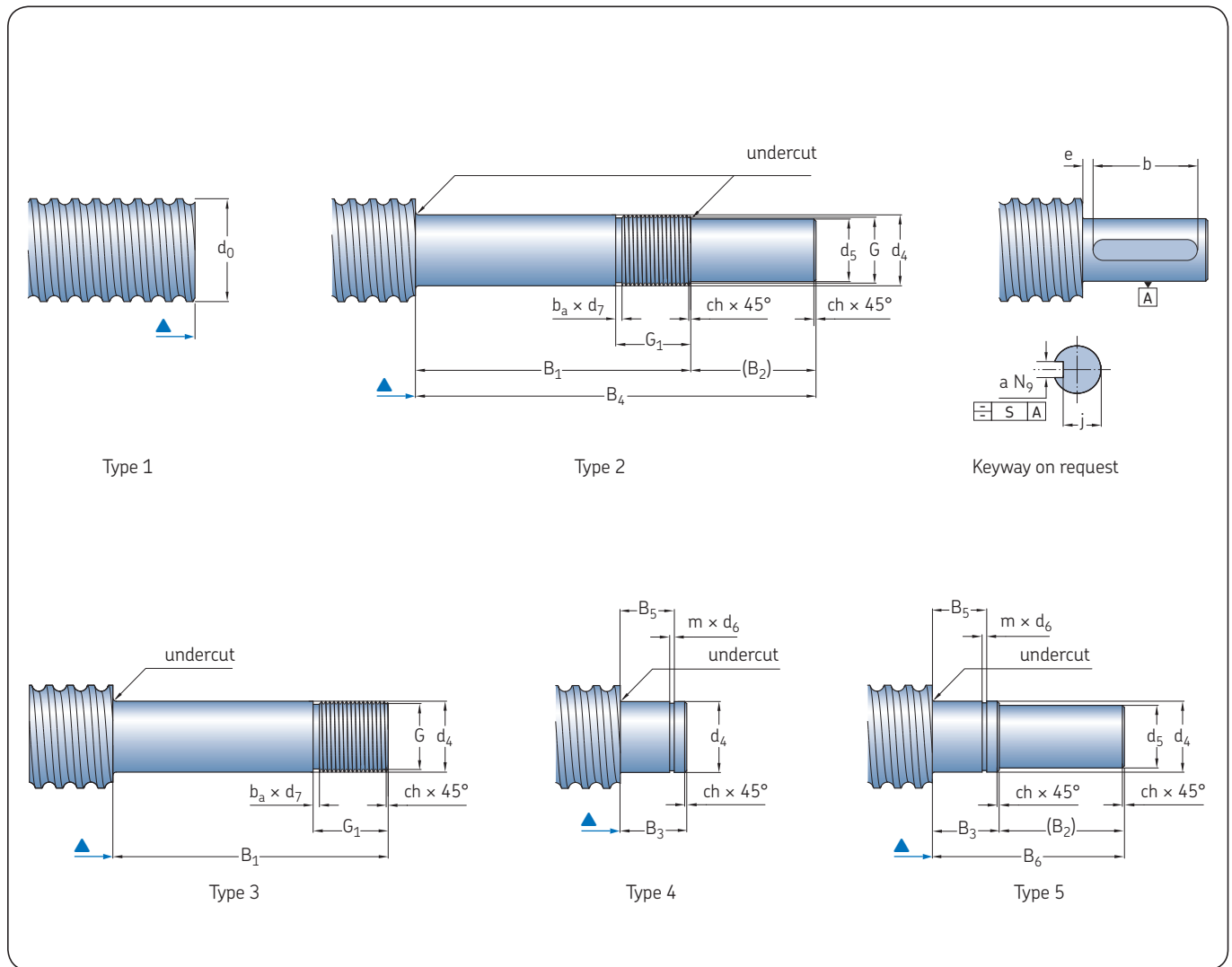

Dimensions

d_0	d_5 h7	$d_4^{1)}$ js7	B_1 js12	B_2	B_3 js12	B_4 js12	B_5 H11	B_6 js12	G 6g	G_1	m +0,14 0	d_6 h11/ h12	ch	b_a	d_7 h11	a N9	b +0,5 0	e	j	S	Keyway DIN 6885
6	3	4	22	10	7	32	5,4	17	M4x0,7	7	0,5	3,8	0,5	1,2	2,9	-	-	-	-	-	-
8	4	5	24	12	7	36	5,6	19	M5x0,8	7,2	0,7	4,8	0,5	1,2	3,7	-	-	-	-	-	-
10	5	6	26	12	9	38	6,7	21	M6x1	7,5	0,8	5,7	0,5	1,5	4,5	-	-	-	-	-	-
12/12,7	6	8	38	12	10	50	7,8	22	M8x1	12,5	0,9	7,6	0,5	1,5	6,5	2	8	3	4,8	0,1	A2x2x8
14	8	10	40	16	12	56	9	28	M10x1,5	13,3	1,1	9,6	0,5	2,3	7,8	2	10	3	6,8	0,1	A2x2x10

¹⁾ For applications with radial loads on support bearings, please consult SKF for best selection of tolerance on diameter d_4

Standard end machining for shaft nominal diameter ≥ 16 mm

For SD/BD-SDS/BDS-SX/BX-SND/BND/PND-SN/BN/PN

Standard shaft ends for ball screws with nominal diameter $d_0 \geq 16$ mm have been developed to fit with the SKF support bearings FLBU, PLBU and BUF.

Support bearing	Machined end type
FLBU	2A or 3A
PLBU	2A or 3A
BUF	4A or 5A

For these types of machined ends, the maximum permissible dynamic load is 75% of the ball screw dynamic load carrying capacity.

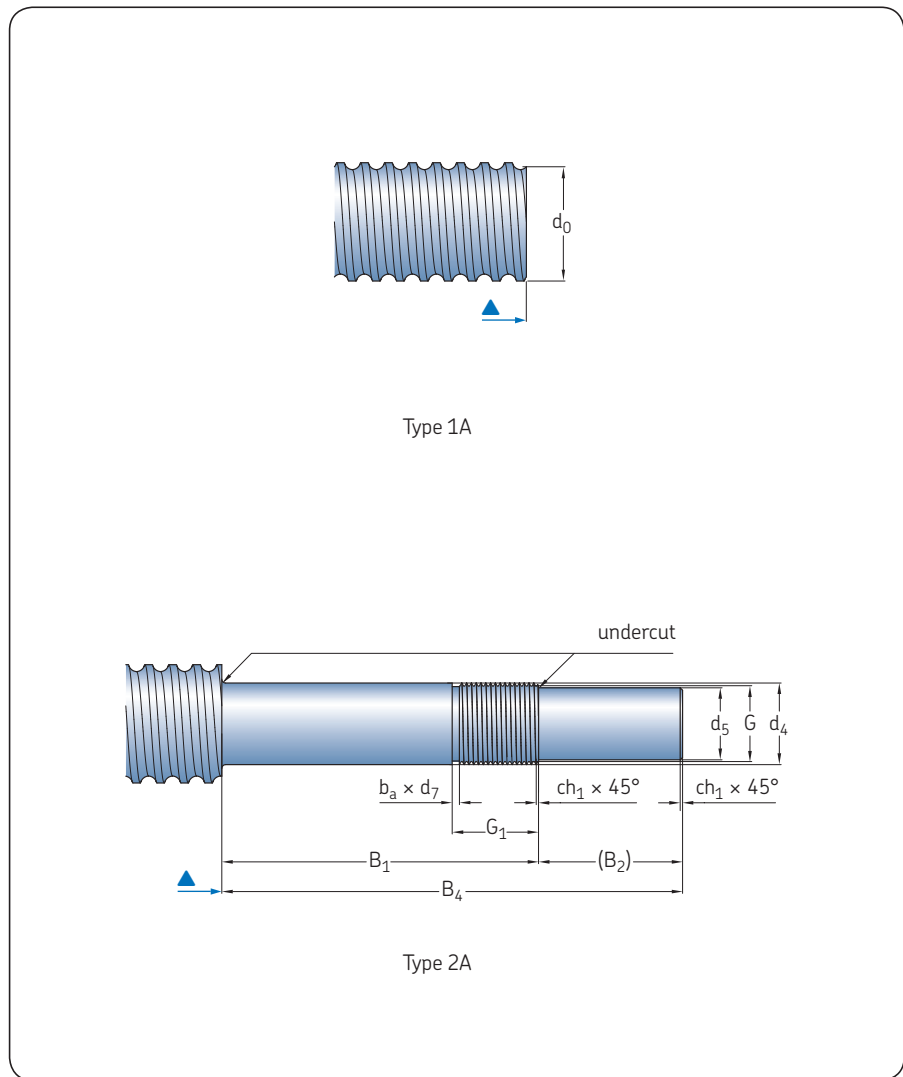

Size

d_0	d_5	$d_4^{1)}$	d_{11}	d_{12}	B_1	B_2	B_3	B_4	B_5	B_6	B_7	d_8
-	h7	h6	h6	h7	js12		js12	js12	H11	js12		
mm												
16	8	10	10	8	53	16	13	69	10	29	2	12,5
20	10	12	10	8	58	17	13	75	10	29	2	14,5
25 ¹⁾	15	17	17	15	66	30	16	96	13	46	4,5	20
32 ¹⁾	17	20	17	15	69	30	16	99	13	46	4,5	21,7
40 ¹⁾	25	30	30	25	76	45	22	121	17,5	67	4,5	33,5
50 ¹⁾	30	35	30	25	84	55	22	139	17,5	67	4,5	35,2
63	40	50	45	40	114	65	28	179	20,75	93	3	54

¹⁾ For applications with radial loads on support bearings, please consult SKF for best selection of tolerance on diameter d_4

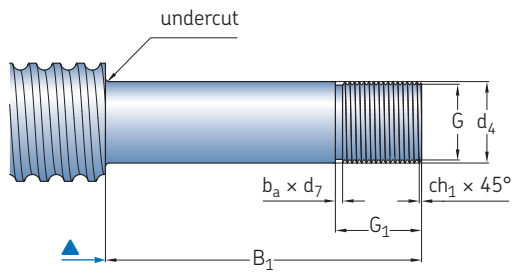

Type 3A

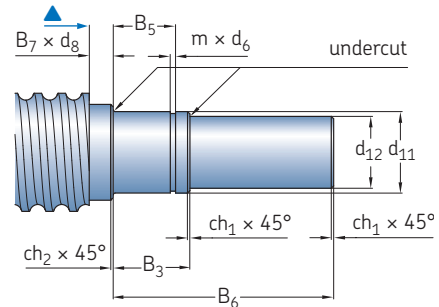

Type 5A

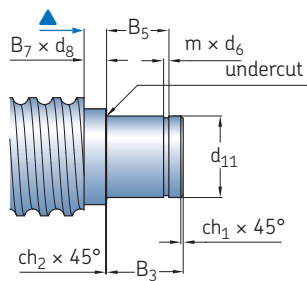

Type 4A

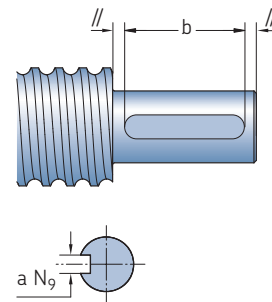

Keyway on request

Size

Keyway to DIN 6885

d_0	G 6g	G_1	m +0,14 0	d_6 h11	h_{12}	ch_1	ch_2	b_a	d_7 h11	$a^{N9} \times l \times b$	
										fixed end (type 2A)	fixed end (type 5A)
16	M10×0,75	17	1,1	9,6		0,5	0,5	1,2	8,8	A2×2×12	A2×2×12
20	M12×1	18	1,1	9,6		0,5	0,5	1,5	10,5	A3×3×12	A2×2×12
25	M17×1	22	1,1	16,2		0,5	0,5	1,5	15,5	A5×5×25	A5×5×25
32	M20×1	22	1,1	16,2		0,5	0,5	1,5	18,5	A5×5×25	A5×5×25
40	M30×1,5	25	1,6		28,6	1	0,5	2,3	27,8	A8×7×40	A8×7×40
50	M35×1,5	27	1,6		28,6	1	0,5	2,3	32,8	A8×7×45	A8×7×40
63	M50×1,5	32	1,85		42,5	1,5	1	2,3	47,8	A12×8×50	A12×8×50

Standard end machining for SL/TL only

Standard shaft ends for SL/TL ball screws have been developed to fit with the SKF support bearings FLBU, PLBU and BUF.

For the SL/TL long lead screw, an additional centering diameter, part of the threaded length, will be machined at both ends of the screw shaft to facilitate the nut assembly.

Support bearing	Machined end type
FLBU	2A or 3A
PLBU	2A or 3A
BUF	4A or 5A

For these types of machined ends, the maximum permissible dynamic load is 75% of the ball screw dynamic load carrying capacity, except for size 50x50 for which the dynamic load must not exceed 40 kN.

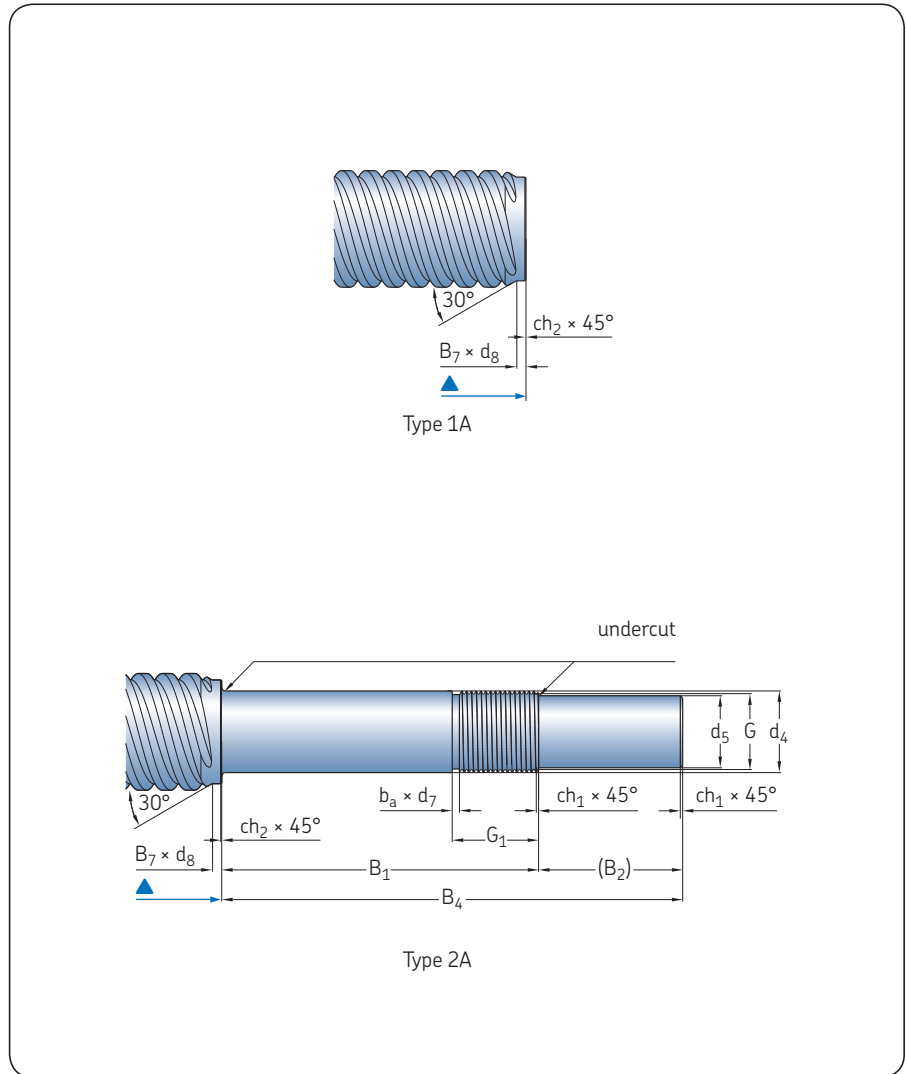

Size

d_0	d_5	$d_4^{1)}$	d_{10}	d_{11}	d_{12}	B_1	B_2	B_3	B_4	B_5	B_6	B_7	B_9	d_8
-	h_7	h_6		h_6	h_7	js_{12}		js_{12}	js_{12}	H11	js_{12}			
mm														
25x20	15	17	-	17	15	66	30	16	96	13	46	4,5	0	21,6
25x25	15	17	-	17	15	66	30	16	96	13	46	4,5	0	21,4
32x20	17	20	21,5	17	15	69	30	16	99	13	46	4,5	2	27,3
32x32	17	20	21,5	17	15	69	30	16	99	13	46	4,5	2	28,3
32x40	17	20	21,5	17	15	69	30	16	99	13	46	4,5	2	26,8
40x20	25	30	-	30	25	76	45	22	121	17,5	67	6,5	0	35,1
40x40	25	30	-	30	25	76	45	22	121	17,5	67	6,5	0	34,1
50x50	30	35	37	30	25	84	55	22	139	17,5	67	9	3	43,3

¹⁾ For applications with radial loads on support bearings, please consult SKF for best selection of tolerance on diameter d_4

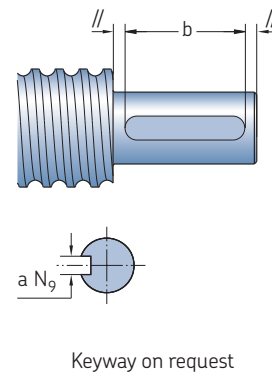
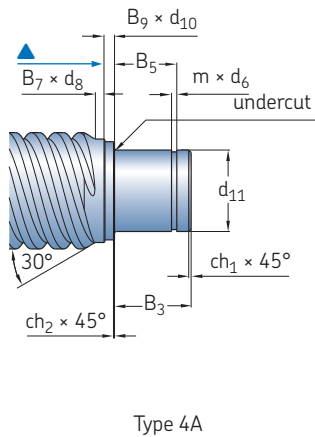
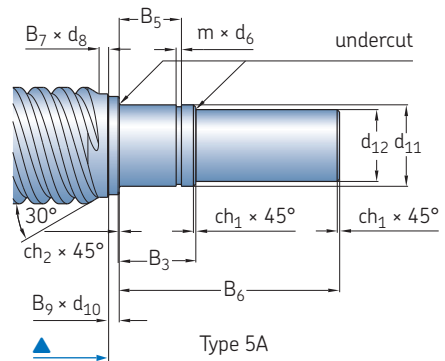
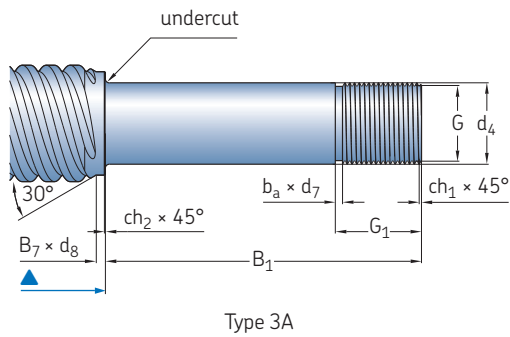

Size

Keyway to DIN 6885

$d_0 \times P_h$	G 6g	G_1	m +0,14 0	d_6 h11	h12	ch_1	ch_2	b_a	d_7 h11	$a^{N9} \times l \times b$ fixed end (type 2A)	fixed end (type 5A)
25×20	M17×1	22	1,1	16,2	–	0,5	0,5	1,5	15,5	A5×5×25	A5×5×25
25×25	M17×1	22	1,1	16,2	–	0,5	0,5	1,5	15,5	A5×5×25	A5×5×25
32×20	M20×1	22	1,1	16,2	–	0,5	0,5	1,5	18,5	A5×5×25	A5×5×25
32×32	M20×1	22	1,1	16,2	–	0,5	0,5	1,5	18,5	A5×5×25	A5×5×25
32×40	M20×1	22	1,1	16,2	–	0,5	0,5	1,5	18,5	A5×5×25	A5×5×25
40×20	M30×1,5	25	1,6	–	28,6	1	0,5	2,3	27,8	A8×7×40	A8×7×40
40×40	M30×1,5	25	1,6	–	28,6	1	0,5	2,3	27,8	A8×7×40	A8×7×40
50×50	M35×1,5	27	1,6	–	28,6	1	0,5	2,3	32,8	A8×7×45	A8×7×40

▲ End of threaded screw length

FLBU ball screw support bearings

Axially locating flanged housings fitted with SKF angular contact ball bearings

Features

- Precision machined housing made of bur-nished steel
- Two SKF preloaded angular contact ball bearings, 72 or 73 series, in back-to-back arrangement
- Two garter seals
- Standard self-locking Nylstop nut or high precision KMT nut upon request.

Benefits

- Complete support bearing ready to use, simplified application design, easy ordering process
- Quick assembly onto shaft end
- Elimination of most technical risks with bearings and seals assembly
- Support bearing dimensions and load carrying capacity matched to the ball screw characteristics
- Bearings back-to-back assembly with preload for stiff and accurate ball screw positioning
- Greased for life / maintenance-free.

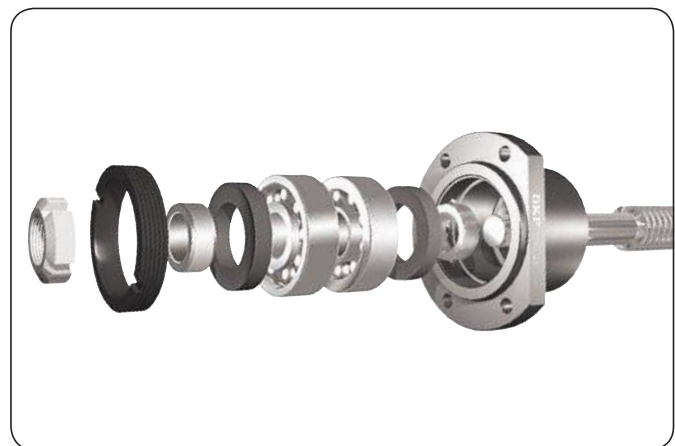

Nominal diameter d_0	Angular contact ball bearing (40°)			SKF bearing designation	Lock nut		High precision nut ³⁾		Tightening torque	Grub screws size	tightening torque max.	Flanged support bearing designation
	Basic load rating (axial) dynamic C_a	static C_{0a}	Axial stiffness		Self-locking nut Designation	Hook spanner	Designation	Hook spanner				
mm	kN		N/ μ m	–	–	–	–	Nm	–	Nm	–	
16	12,2	12,8	play	7200 BECB ¹⁾	CN 70-10	HN 1	KMT 0	HN 2/3	4	M5	4,5	FLBU 16
20	13,3	14,7	125	7201 BEGA ²⁾	CN 70-12	HN 1	KMT 1	HN 3	8	M5	4,5	FLBU 20
25	27,9	31,9	150	7303 BEGA ²⁾	CN 70-17	HN3	KMT 3	HN 4	15	M6	8	FLBU 25
32	24,6	31,9	176	7204 BEGA ²⁾	CN 70-20	HN 4	KMT 4	HN 5	18	M6	8	FLBU 32
40	41,9	59,6	222	7206 BEGA ²⁾	CN 70-30	HN 6	KMT 6	HN 6	32	M6	8	FLBU 40
50	54,5	79,8	250	7207 BEGA ²⁾	CN 70-35	HN 7	KMT 7	HN 7	40	M6	8	FLBU 50
63	128	196,1	353	7310 BEGA ²⁾	CN 70-50	HN 10	KMT 10	HN 10/11	60	M8	18	FLBU 63

¹⁾ No backlash elimination

²⁾ Light preload

³⁾ Optional

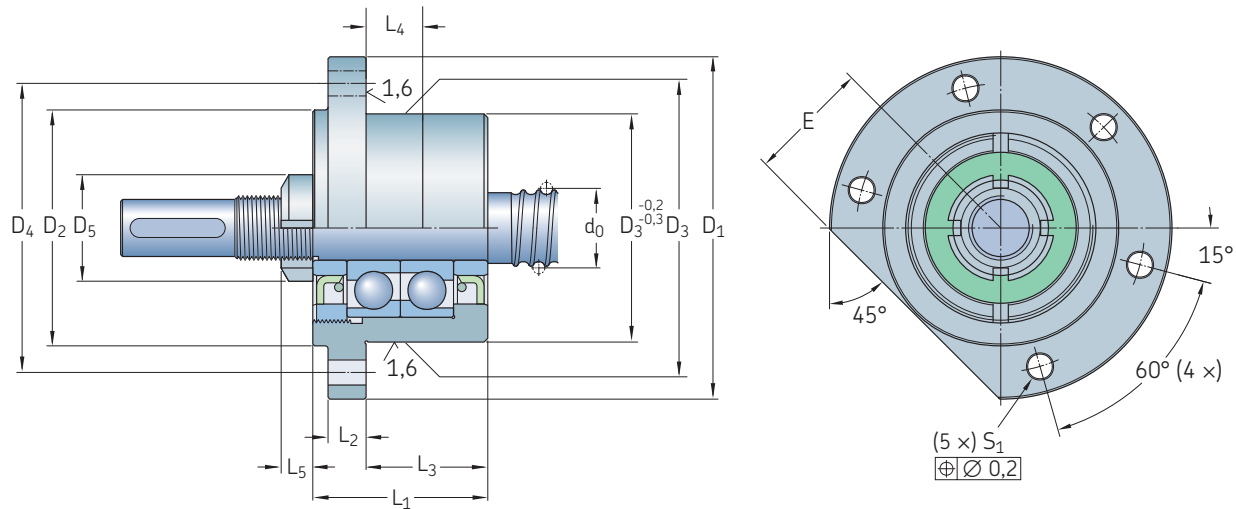

Screw Support bearing

d ₀	L ₁	L ₂	L ₃	L ₄	Self-locking nut		High precision nut ⁴⁾			D ₁	D ₂	D ₃ h7	D ₄	S ₁ H13	E	Fixing screws
					L ₅	D ₅	L ₅	D ₅	D ₅							
mm	mm															
16	37	10	22	12	7	18	14	28	76	50	47	63	6,6	26	M6×30	
20	42	10	25	12	7,5	21	14	30	76	50	47	63	6,6	27	M6×30	
25	46	10	32	18	8,3	28	18	37	90	62	60	76	6,6	32	M6×30	
32	49	13	32	18	8,3	32	18	40	90	59	60	74	9	32	M8×40	
40	53	16	32	18	11	44	20	49	120	80	80	100	11	44	M10×45	
50	59	20	32	18	11	50	22	54	130	89	90	110	13	49	M12×60	
63	85	25	43,5	22	11,7	68	25	75	165	124	124	146	13	64	M12×60	

⁴⁾ Optional

PLBU ball screw support bearings

Fixed pillow blocks fitted with SKF angular contact ball bearings

Features

- Precision machined housing made of bur-nished steel
- Precision machined side faces of the housing can be used as reference assembly surfaces for screw alignment
- Two SKF preloaded angular contact ball bearings, 72 or 73 series, in back-to-back arrangement
- Two garter seals
- Standard self-locking Nylstop nut or high precision KMT nut upon request.

Benefits

- Complete support bearing ready to use, simplified application design, easy ordering process
- Quick assembly onto shaft end
- Elimination of most technical risks with bearings and seals assembly
- Support bearing dimensions and load carrying capacity matched to the ball screw characteristics
- Bearings back-to-back assembly with preload for stiff and accurate ball screw positioning
- Good rigidity provided by the base mounting with dowel pins
- Greased for life / maintenance-free.

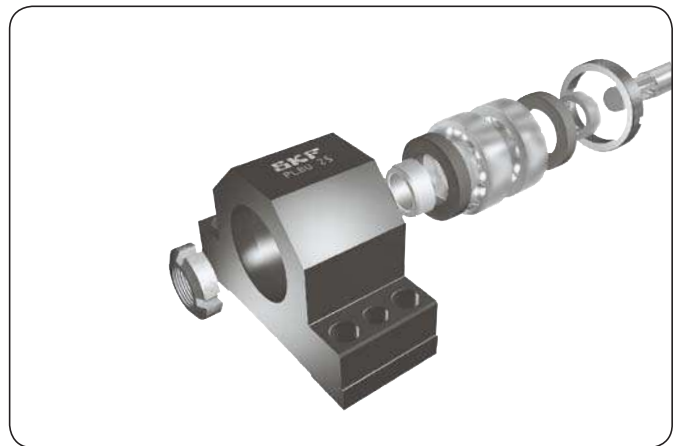
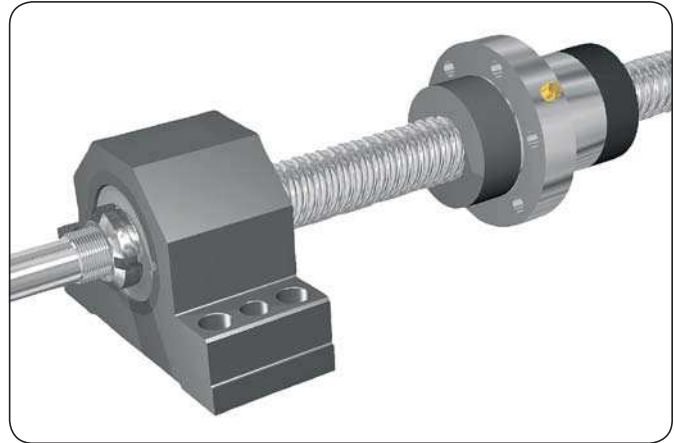

Nominal diameter	Angular contact ball bearing (40°)			SKF bearing designation	Lock nut		High precision nut ³⁾		Tightening torque	Grub screws size	Grub screws tightening torque max.	Pillow block designation
	Basic load rating (axial) dynamic	Basic load rating (axial) static	Axial stiffness		Self-locking nut Designation	Hook spanner	Designation	Hook spanner				
d ₀	C _a	C _{0a}	N/μm	–	–	–	–	–	Nm	–	Nm	–
16	12,2	12,8	play	7200 BECB ¹⁾	CN 70-10	HN 1	KMT 0	HN 2/3	4	M5	4,5	PLBU 16
20	13,3	14,7	125	7201 BEGA ²⁾	CN 70-12	HN 1	KMT 1	HN 3	8	M5	4,5	PLBU 20
25	27,9	31,9	150	7303 BEGA ²⁾	CN 70-17	HN3	KMT 3	HN 4	15	M6	8	PLBU 25
32	24,6	31,9	176	7204 BEGA ²⁾	CN 70-20	HN 4	KMT 4	HN 5	18	M6	8	PLBU 32
40	41,9	59,6	222	7206 BEGA ²⁾	CN 70-30	HN 6	KMT 6	HN 6	32	M6	8	PLBU 40
50	54,5	79,8	250	7207 BEGA ²⁾	CN 70-35	HN 7	KMT 7	HN 7	40	M6	8	PLBU 50
63	128	196,1	353	7310 BEGA ²⁾	CN 70-50	HN 10	KMT 10	HN 10/11	60	M8	18	PLBU 63

¹⁾ No backlash elimination

²⁾ Light preload

³⁾ Optional

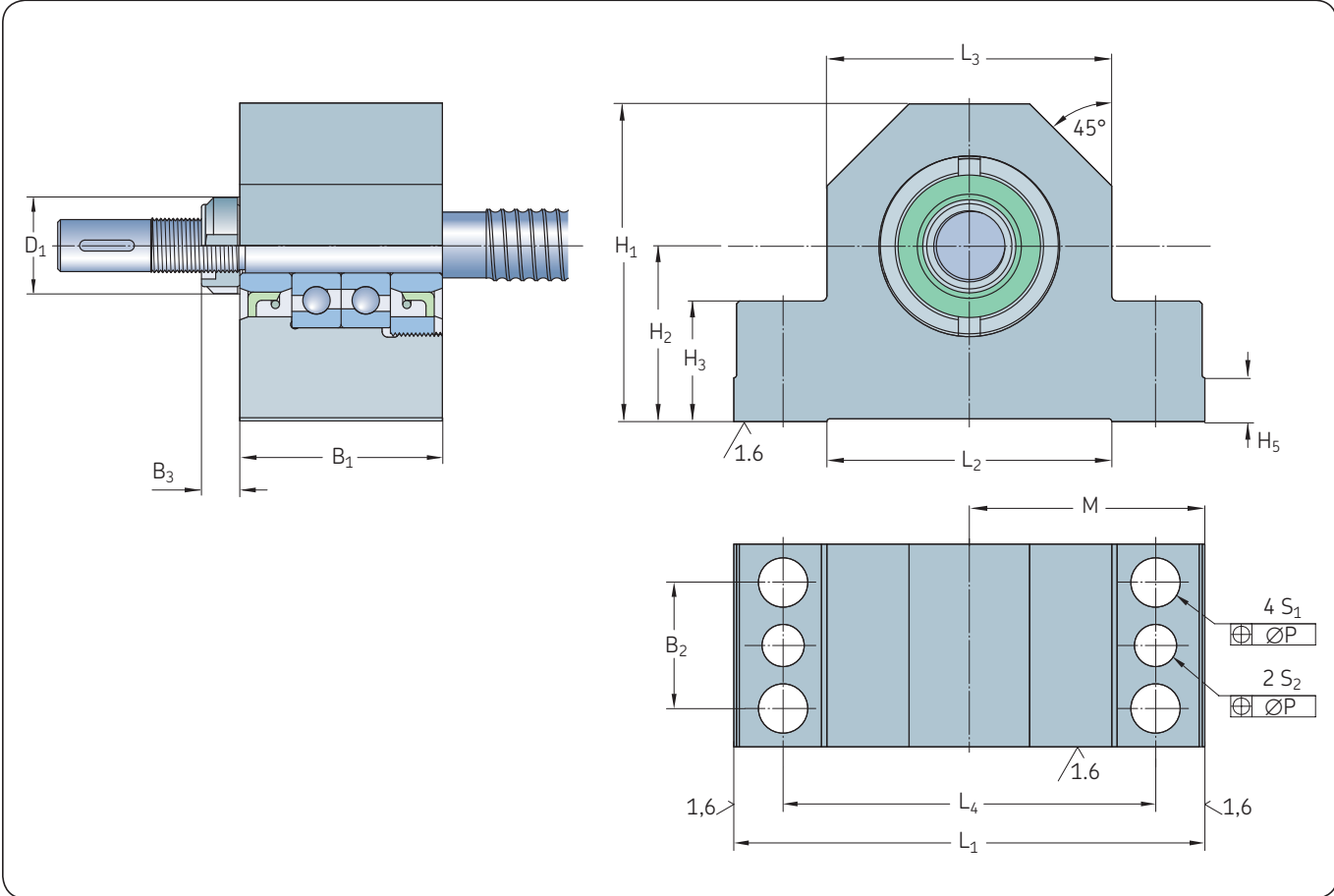

Screw Support bearing

d_0	L_1	L_2	L_3	L_4	M js8	B_1	B_2	Self-locking nut B_3	High precision nut ⁴⁾ D_1	B_3	D_1	H_1	H_2 js8	H_3	H_4	H_5	S_1	P	S_2 H12	Fixing screws	Tapered pin (hardened) or straight pin (DIN6325)	
mm	mm																					
16	86	52	52	68	43	37	23	7,0	18	14	28	58	32	22	15	8	9	0,15	7,7	M8x35	8x40	
20	94	52	60	77	47	42	25	7,5	21	14	30	64	34	22	17	8	9	0,15	7,7	M8x35	8x40	
25	108	65	66	88	54	46	29	8,3	28	18	37	72	39	27	19	10	11	0,20	9,7	M10x40	10x50	
32	112	65	70	92	56	49	29	8,3	32	18	40	77	45	27	20	10	11	0,20	9,7	M10x40	10x50	
40	126	82	80	105	63	53	32	11,0	44	20	49	98	58	32	23	12	13	0,20	9,7	M12x50	10x50	
50	144	80	92	118	72	59	35	11,0	50	22	54	112	65	38	25	12	13	0,20	9,7	M12x55	10x55	
63	190	110	130	160	95	85	40	11,7	68	25	75	130	65	49	35	15	13	0,20	9,7	M12x65	10x65	

⁴⁾ Optional

BUF ball screw support bearings

Axially free pillow blocks fitted with SKF deep groove ball bearing

Features

- Precision machined housing made of bur-nished steel
- Precision machined side faces of the housing can be used as reference assembly surfaces for screw alignment
- One SKF deep groove ball bearing of type 62...2RS1
- Bearing is sealed and greased for life
- Retaining ring is supplied with the BUF assembly.

Benefits

- Complete support bearing ready to use, simplified application design, easy ordering process
- Quick assembly onto shaft end
- Elimination of most technical risks with bearings and seals assembly
- Greased for life / maintenance-free.

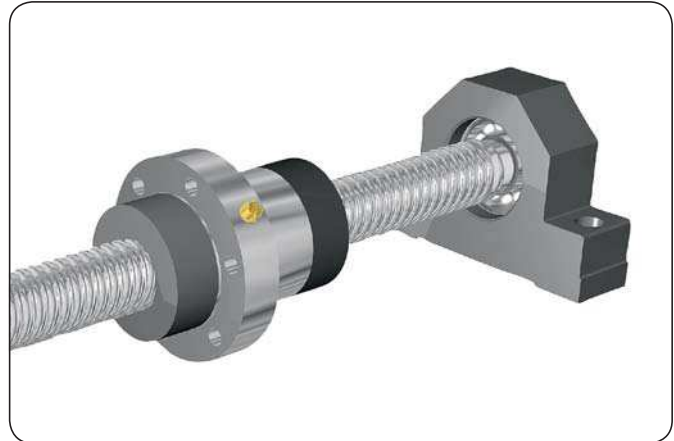

Nominal diameter	Deep groove ball bearing		SKF bearing designation	Dimensions			Retaining ring (DIN 471)	Pillow block designation
	Basic load rating radial			d	D	B		
d_0	C	C_0		d	D	B		
mm	kN	kN	–	mm	mm	mm	–	–
16	5,07	2,36	6200.2RS1	10	30	9	10×1	BUF 16
20	5,07	2,36	6200.2RS1	10	30	9	10×1	BUF 20
25	9,56	4,75	6203.2RS1	17	40	12	17×1	BUF 25
32	9,56	4,75	6203.2RS1	17	40	12	17×1	BUF 32
40	19,5	11,2	6206.2RS1	30	62	16	30×1,5	BUF 40
50	19,5	11,2	6206.2RS1	30	62	16	30×1,5	BUF 50
63	33,2	21,6	6209.2RS1	45	85	19	45×1,75	BUF 63

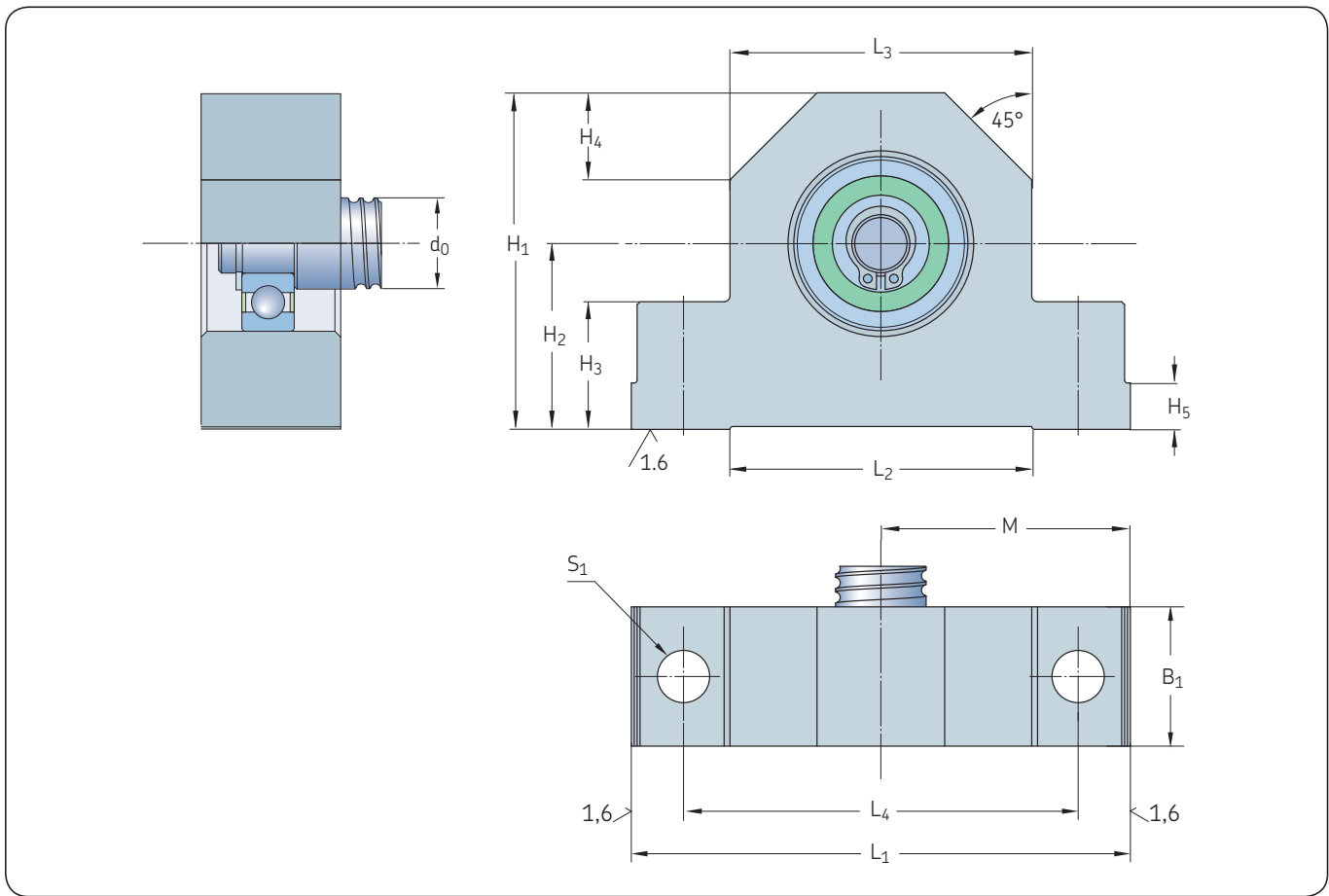

Screw Support bearing

d ₀	L ₁	L ₂	L ₃	L ₄	M js8	B ₁	H ₁	H ₂ js8	H ₃	H ₄	H ₅	S ₁ H12	Fixing screws
													-
16	86	52	52	68	43	24	58	32	22	15	8	9	M8×35
20	94	52	60	77	47	26	64	34	22	17	8	9	M8×35
25	108	65	66	88	54	28	72	39	27	19	10	11	M10×40
32	112	65	70	92	56	34	77	45	27	20	10	11	M10×40
40	126	82	80	105	63	38	98	58	32	23	12	13	M12×50
50	144	80	92	118	72	39	112	65	38	25	12	13	M12×55
63	190	110	130	160	95	38	130	65	49	35	15	13	M12×65

Examples of customized nuts



SD rotating nut with flange and bearing journals



SDS nut with integrated trunnions



SN rotating nut with flange and bearing journals



PN nut with customized compact flange



SL nut with customized flange attachment

Manufacturing tolerances

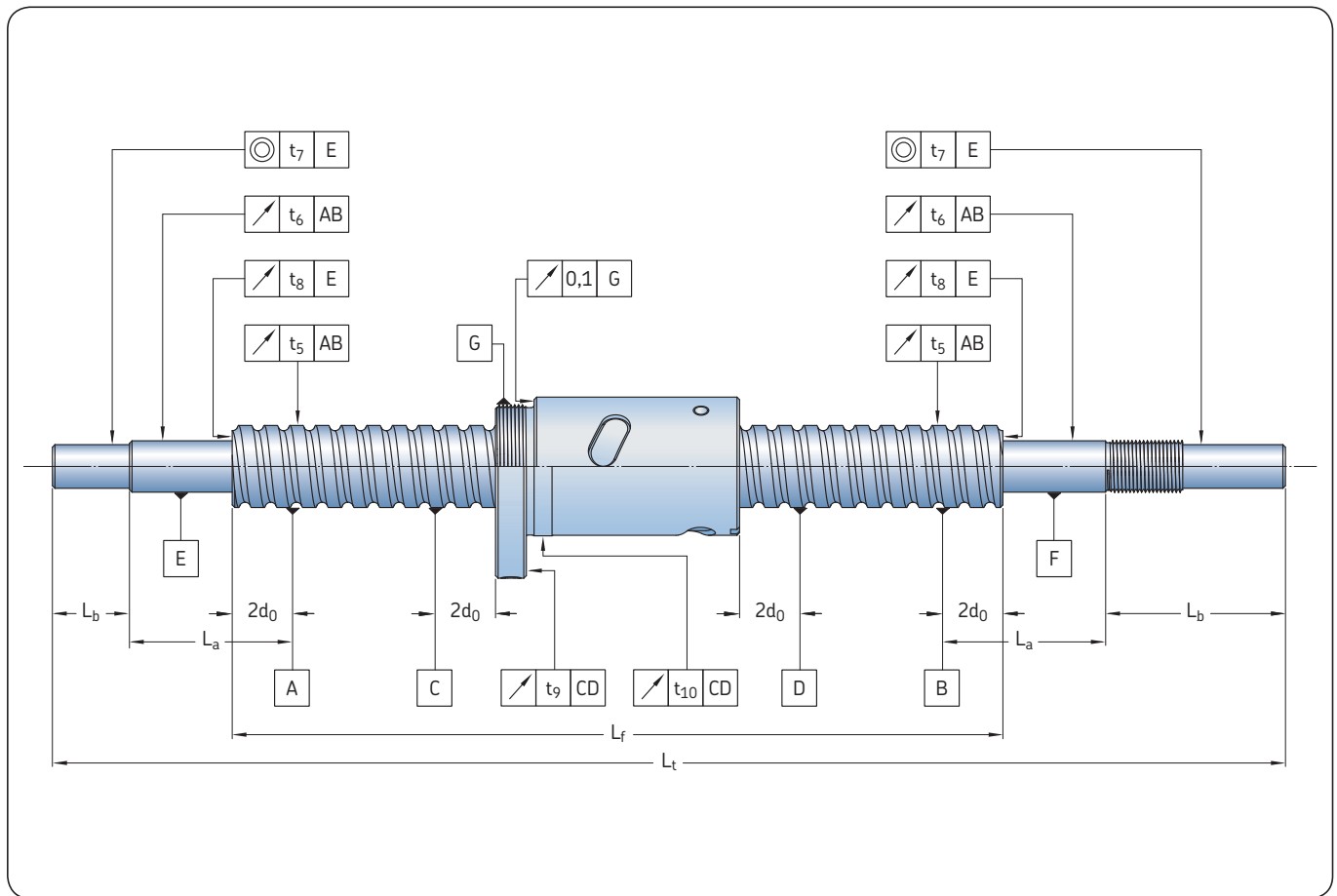

Nomineller Durchmesser		Reference lengths		Tolerances						Ratio		Tolerance
$d_0 >$	$d_0 \leq$	$L_{f\text{ref}}$	$L_{a\text{ref}}$ and $L_{b\text{ref}}$	t_{5p}	t_{6p}	t_{7p}	t_8	t_9	t_{10}	$L_f / d_0 >$	$L_f / d_0 \leq$	t_5
mm		μm										
6	12	80	80	40	40	12	6			-	40	80
12	16	160	80	40	40	12	6	20	20	40	60	120
16	20	160	80	40	40	12	6	20	25	60	80	200
20	25	160	125	40	50	16	6	20	25	80	100	320
25	40	315	125	40	50	16	6	25	25			
40	50	315	125	40	50	16	6	25	32			
50	63	630	200	40	63	20	6	25	32			

Value for t_5

- if $L_f \leq L_{f\text{ref}}$ $t_5 = t_{5p}$
- if $L_f > L_{f\text{ref}}$ t_5

Value for t_6

- if $L_a \leq L_{a\text{ref}}$ $t_6 = t_{6p}$
- if $L_a > L_{a\text{ref}}$ $t_6 = (L_a / L_{a\text{ref}}) t_{6p}$

Value for t_7

- if $L_b \leq L_{b\text{ref}}$ $t_7 = t_{7p}$
- if $L_b > L_{b\text{ref}}$ $t_7 = (L_b / L_{b\text{ref}}) t_{7p}$

Calculation formulae

Basic life rating

$$L_{10} = \left(\frac{C_a}{F_m} \right)^3$$

Required load rating

$$C_{req} = F_m (L_{10})^{1/3}_{req}$$

where

L_{10} = life [million revolutions]

C_a = basic dynamic load rating [N]

C_{req} = required dynamic load rating [N]

F_m = cubic mean load [N]

Equivalent mean load

- Duty cycle with step loading

$$F_m = \frac{(F_1^3 L_1 + F_2^3 L_2 + F_3^3 L_3 + \dots)^{1/3}}{(L_1 + L_2 + L_3 + \dots)^{1/3}}$$

where

L_n = load period n (→ diagram 2)

F_n = load during period n (→ diagram 2)

F_n can be a fixed value, or F_n can be calculated using the following formulae for F_m

- Duty cycle with continuous load variation

$$F_m = \frac{F_{min} + 2F_{max}}{3}$$

where

F_{min} = minimum load (→ diagram 3)

F_{max} = maximum load (→ diagram 3)

Critical speed of screw shaft (no safety factor)

$$n_{cr} = 49 \times 10^6 \frac{f_1 d_2}{l^2}$$

where

n_{cr} = critical speed [rpm]

d_2 = root diameter [mm]

l = free length, or distance between the two support bearings [mm]

f_1 = mounting correction factor

0,9 ●●— fixed, free

3,8 ●●—● fixed, radial support

5,6 ●●—●● fixed, fixed

Note: it is generally recommended to apply a safety factor of 0,8 to the calculated value of the critical speed n_{cr} of the screw shaft.

Speed limit of the mechanism (maximal speed applied through very short periods)

With recirculation by inserts / tubes (SD/BD/SH-SDS/BDS/SHS-SX/BX -SND/BND/PND-SN/BN/PN):

$$n d_0 < 50\,000$$

With recirculation through flange (SL/TL-SLD/TLD):

$$n d_0 < 90\,000$$

If $n d_0 > 50\,000$ or $90\,000$ respectively, please consult SKF

where

n = rotational speed [rpm]

d_0 = screw shaft nominal diameter [mm]

Maximum admissible acceleration is

$$4\,000 \text{ rad/s}^2$$

Buckling strength, with safety factor 3

$$F_c = \frac{34 \times 10^3 f_3 d_2^4}{l^2}$$

where

F_c = buckling strength [N]

d_2 = root diameter [mm]

l = free length, or distance between the two support bearings [mm]

f_3 = mounting correction factor

0,25 ●●— fixed, free

2 ●●—● fixed, radial support

4 ●●—●● fixed, fixed

Diagram 2

Equivalent mean load

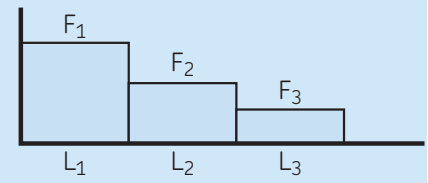

Diagram 3

Equivalent mean load

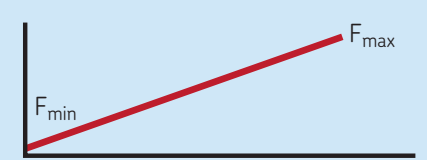

Fig. 11

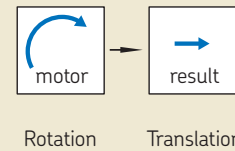

Fig. 12

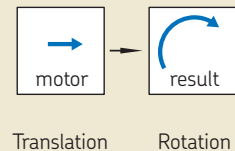

Fig. 13

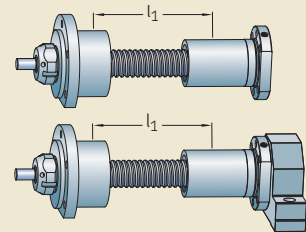
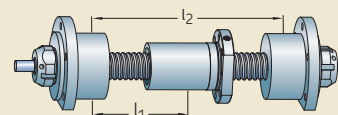

Fig. 14



Theoretical efficiencies

Direct (→ fig. 11)

$$\eta = \frac{1}{1 + \frac{\pi d_0}{P_h} \mu}$$

where

$\mu = 0,0065$ for SH/SHS

$\mu = 0,006$ for SD/BD, SDS/BDS, SX/BX, SND/BND/PND, SN/BN/PN, SL/TL, SLT/TLT

d_0 = nominal diameter of screw shaft [mm]

P_h = lead [mm]

Indirect (→ fig. 12)

$$\eta' = 2 - \frac{1}{\eta}$$

Practical efficiency

$$\eta_p = 0,9 \eta$$

The value 0,9 is an average value between the practical efficiency of a new screw and that of a properly run-in screw.

It should be used for industrial applications in all normal working conditions. For extreme cases, please contact SKF.

Input torque in a steady state

$$T = \frac{F P_h}{2\,000 \pi \eta_p}$$

where

T = input torque [Nm]

F = maximum load of the cycle [N]

P_h = lead [mm]

η_p = practical efficiency

Power requirement in a steady state

$$P = \frac{F n P_h}{60\,000 \eta_p}$$

where

P = power required [W]

n = revolutions per minute [rpm]

Preload torque [Nm]

$$T_{pr} = \frac{F_{pr} P_h}{1\,000 \pi} \left(\frac{1}{\eta_{pr}} - 1 \right)$$

where

T_{pr} = preload torque [N]

F_{pr} = preload [N]

η_{pr} is calculated using $\mu = 0,01$ for preloaded system

Restraining torque (considering a back-driving system)

$$T_B = \frac{F P_h \eta'}{2\,000 \pi}$$

where

T_B = restraining torque [Nm]

F = load [N]

For safety reasons, we use the theoretical indirect efficiency.

Nominal motor torque during acceleration

For a horizontal screw

$$T_t = T_f + T_{pr} + \frac{P_h [F + m_L \mu_f g]}{2\,000 \pi \eta_p} + \dot{\omega} \Sigma I$$

For a vertical screw

$$T_t = T_f + T_{pr} + \frac{P_h [F + m_L g]}{2\,000 \pi \eta_p} + \dot{\omega} \Sigma I$$

where

T_t = nominal torque [Nm]

T_f = torque from friction in support bearings, motors, seals, etc... [Nm]

T_{pr} = preload torque [Nm]

μ_f = coefficient of friction

$\dot{\omega}$ = angular acceleration [rad/s²]

m_L = mass of the load [kg]

g = acceleration of gravity [9,8 m/s²]

$\Sigma I = I_M + I_L + I_S l \cdot 10^{-9}$

Nominal braking torque during deceleration

For a horizontal screw

$$T'_t = T_f + T_{pr} + \frac{P_h \eta' [F + m_L \mu_f g]}{2\,000 \pi} + \dot{\omega} \Sigma I$$

For a vertical screw

$$T'_t = T_f + T_{pr} + \frac{P_h \eta' [F + m_L g]}{2\,000 \pi} + \dot{\omega} \Sigma I$$

where

$$I_L = m_L \left(\frac{P_h}{2 \pi} \right)^2 10^{-6}$$

where

I_M = inertia of motor [kgm²]

I_S = inertia of screw shaft per metre [kgmm²/m]

l = length of screw shaft [mm]

Static axial stiffness of a complete ball screw assembly

$$\frac{1}{R_t} = \frac{1}{R_s} + \frac{1}{R_n} + \frac{1}{R_p}$$

where

R_t = stiffness of a complete assembly [N/μm]

R_s = shaft stiffness [N/μm]

R_n = nut stiffness [N/μm]

R_p = support bearings stiffness [N/μm]

Shaft stiffness

Fixed-free or fixed-radial support

$$R_s = 165 \frac{d_2^2}{l_1} \quad (\rightarrow \text{fig. 13})$$

Fixed-fixed assembly

$$R_s = \frac{165 d_2^2 l_2}{l_1 (l_2 - l_1)} \quad (\rightarrow \text{fig. 14})$$

where

l_1 = distance center of fixed support bearing to center of nut [mm]

l_2 = distance between centers of fixed support bearings

For additional information, please contact SKF.

Calculation example for a ball screw

Description of customer application:

- Ball screw type PND 25 × 5. Ball screw is described (→ page 26): Nut with internal preload, 2 × 3 circuits, dynamic carrying capacity $C_a = 12,7$ kN, and static carrying capacity $C_{0a} = 22,7$ kN
- Screw shaft is horizontally mounted and supported by two support bearings of types PLBU25 and BUF25
- Load cycle as follows:
 - Phase 1: Steady axial load of 3 kN, on travel of 900 mm, with linear speed 100 mm/s, or phase duration of 9 seconds
 - Phase 2: Regular load increase from 3 kN to 7 kN, on travel of 100 mm, with linear speed 10 mm/s, or phase duration of 10 seconds
 - Phase 3: Nut return to initial position, with steady load of 2 kN, on travel of 1 000 mm, with linear speed 100 mm/s, or phase duration of 10 seconds
 - Then period of 31 seconds with zero load, no displacement
 - Operation during 7 hours per day, 5 days per week, 50 weeks per year.

Calculation of equivalent mean load

First, we check that the maximum load from the duty cycle does not create an excessive loading condition that would be detrimental to service life. Please refer to explanation in paragraph “Service life” (→ page 8).

Calculation of basic life rating L_{10}

Fig. 15

Shaft end 2A for PND 25 x 5

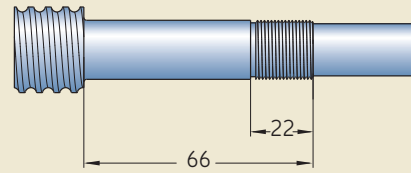
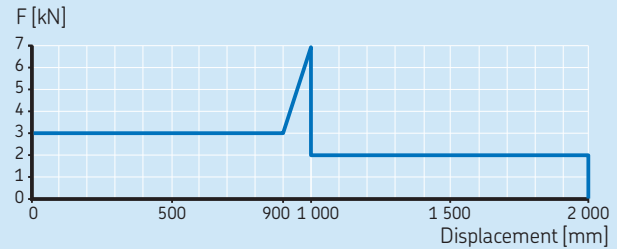
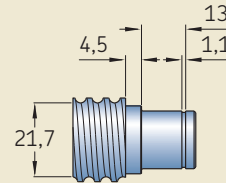

Fig. 16

Shaft end 4A for PND 25 x 5



Maximum application load = 7 kN,
while 60% of $C_a = 60\% \times 12,7 = 7,6$ kN \Rightarrow OK

$$F_1 = 3000 \text{ N} \quad \text{on } L_1 = 900 \text{ mm}$$

$$F_2 = \frac{3000 + 2 \times 7000}{3} = 5667 \text{ N} \quad \text{on } L_2 = 100 \text{ mm}$$

$$F_3 = 2000 \text{ N} \quad \text{on } L_3 = 1000 \text{ mm}$$

$$F_m = \sqrt[3]{\frac{3000^3 \times 900 + 5667^3 \times 100 + 2000^3 \times 1000}{900 + 100 + 1000}}$$

$$= 2934 \text{ N}$$

$$L_{10} = \left(\frac{12700}{2934} \right)^3 = 81,1 \text{ millions revolutions}$$

Number of nut revolutions per one complete cycle
= $(2 \times 1000) / 5 = 400$ revolutions

Or $(81,1 \times 10^6) / 400 = 202750$ complete cycles

One complete cycle lasts $(9 + 10 + 10 + 31) = 60$ seconds

Or life rating of $(202750 \times 60) / (3600 \times 7 \times 5 \times 50) = 1,9$ years
with 90% reliability

Critical speed of screw shaft

The critical speed must be checked, especially when the nut travel is long compared to the shaft diameter. Maximum speed during the duty cycle:

$$V_{\max} = \frac{100}{5} \times 60 = 1\,200 \text{ rpm}$$

The shaft threaded length is calculated with considering the total nut travel (1 000 mm), plus the nut length (62 mm), plus extra free length at each shaft end equal to two leads ($2 \times 2 \times 5 = 20$ mm).

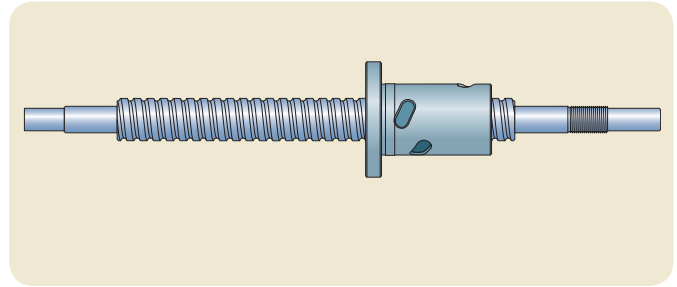

Screw assembly is horizontally mounted. End machining is 2A for support bearing PLBU25, and end machining is type 4A for support bearing BUF25. The combination of 2A + 4A ends machining is called HA when ordering the screw (→ page 36).

So total threaded length = 1 082 mm

For end type 2A, with screw nominal diameter $d_0 = 25$ mm, the central axial position of the bearings is calculated with data from pages 38 and 39:

$(B_1 - G_1) / 2 = (66 - 22) / 2 = 22$ mm from the end of the threaded shaft (→ fig. 15).

For end type 4A, with screw nominal diameter $d_0 = 25$ mm, the central axial position of the bearing is calculated with data from pages 38 and 39:

$B_7 + ((B_5 - m) / 2) = 4,5 + ((13 - 1,1) / 2) \approx 11$ mm from the end of the threaded shaft (→ fig. 16).

The free length between the two support bearings is:

$$l = 1\,082 + 22 + 11 = 1\,115 \text{ mm}$$

The root diameter of the threaded shaft is:

$$d_2 = 21,7 \text{ mm (→ page 27 or 36).}$$

Calculation of critical speed:

$$n_{cr} = 49 \times 10^6 \frac{3,8 \times 21,7}{1\,115^2} = 3\,250 \text{ rpm} > V_{\max} \Rightarrow \text{OK}$$

Speed limit

$$n \times d_0 = 1\,200 \times 25 = 30\,000 < 50\,000 \Rightarrow \text{OK}$$

Buckling strength

$$F_c = \frac{34,10^3 \times 2 \times 21,7^4}{1\,115^2} = 12,1 \text{ kN} > F_{\max} = 7 \text{ kN} \Rightarrow \text{OK}$$

Theoretical direct efficiency

$$\eta = \frac{1}{1 + \frac{\pi \times 25}{5} \times 0,006} = 0,914$$

Theoretical indirect efficiency

$$\eta' = 2 - \frac{1}{0,914} = 0,906$$

Practical efficiency

$$\eta_p = 0,9 \times 0,914 = 0,823$$

Input torque in a steady state

$$T = \frac{7\,000 \times 5}{2\,000 \pi \times 0,823} = 6,8 \text{ Nm}$$

Power requirement in a steady state

$$\text{Phase 1: } P = \frac{3\,000 \times 1\,200 \times 5}{60\,000 \times 0,823} = 365 \text{ W}$$

$$\text{Phase 2: } P = \frac{7\,000 \times 1\,200 \times 5}{60\,000 \times 0,823} = 85 \text{ W}$$

$$\text{Phase 3: } P = \frac{3\,000 \times 1\,200 \times 5}{60\,000 \times 0,823} = 243 \text{ W}$$

Service range

Quick service for precision rolled ball screws

For reduced delivery time, SKF operates quick service facilities in Europe and in North America, where standard screw shafts, nuts and accessories are stocked.

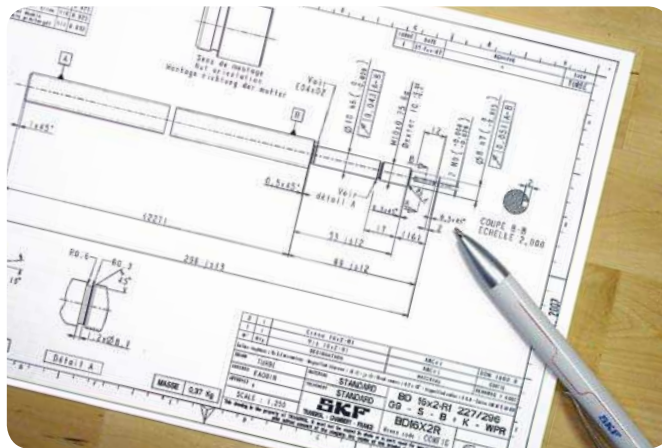

Ball screw orders

Customers can order ball screws with the following options:

- Stock items of screws shafts and nuts, without machined ends. Nuts with axial play mounted on screw shaft, or on sleeve. Nuts with backlash elimination or with preload mounted on shaft
- Ball screw assemblies with shaft ends machined according to standard ends as defined in this catalogue
- Ball screw assemblies with shaft ends machined according to customer requirements: In this case, please send a drawing with all dimensional and tolerance requirements, and with all specifications written in English
- Complete ball screw assemblies, including accessories presented in this catalogue. Accessories already mounted on nut or shaft, or delivered separately.

General rules

Delivery time

- From a couple of days to maximum two weeks is possible for orders fulfilling the following conditions

Quantity

- Maximum 5 pieces for types SX/BX – SND/BND/PND – SN/BN/PN – SL/TL – SLD/TLD
- Maximum 15 pieces for types SD/BD/SH

Materials

- Both shaft and nut should be made of standard steel, as stated in the present catalogue

Capabilities

- Standard nuts, including DIN nuts
- Screw shafts machined according to customer drawing
- Backlash elimination by oversized balls available for BD – BX – BND/BN
- Preload available for PND/PN – TL/TLD
- General precision on tolerances ISO IT7 (ISO 3408-3:2006)
- One nut per screw shaft

Other conditions for quick delivery

- Rotating nut SLT/TLT types are excluded from this program
- Stainless steel or special treatments, including annealed shaft ends, splines are excluded from this program
- Material certificates, special reports, or orders that require special procedure and approval by the French authorities are excluded for this program.

Available range

Diameter	Lead	Nut types	Lead precision	Accessories
From 6 to 63 mm	From 2 to 50 mm	Cylindrical and flanged nuts with axial play, backlash elimination, or preload, SKF designs or DIN designs	G5 – G7 – G9	Flanges for nuts, and ball screw support bearings

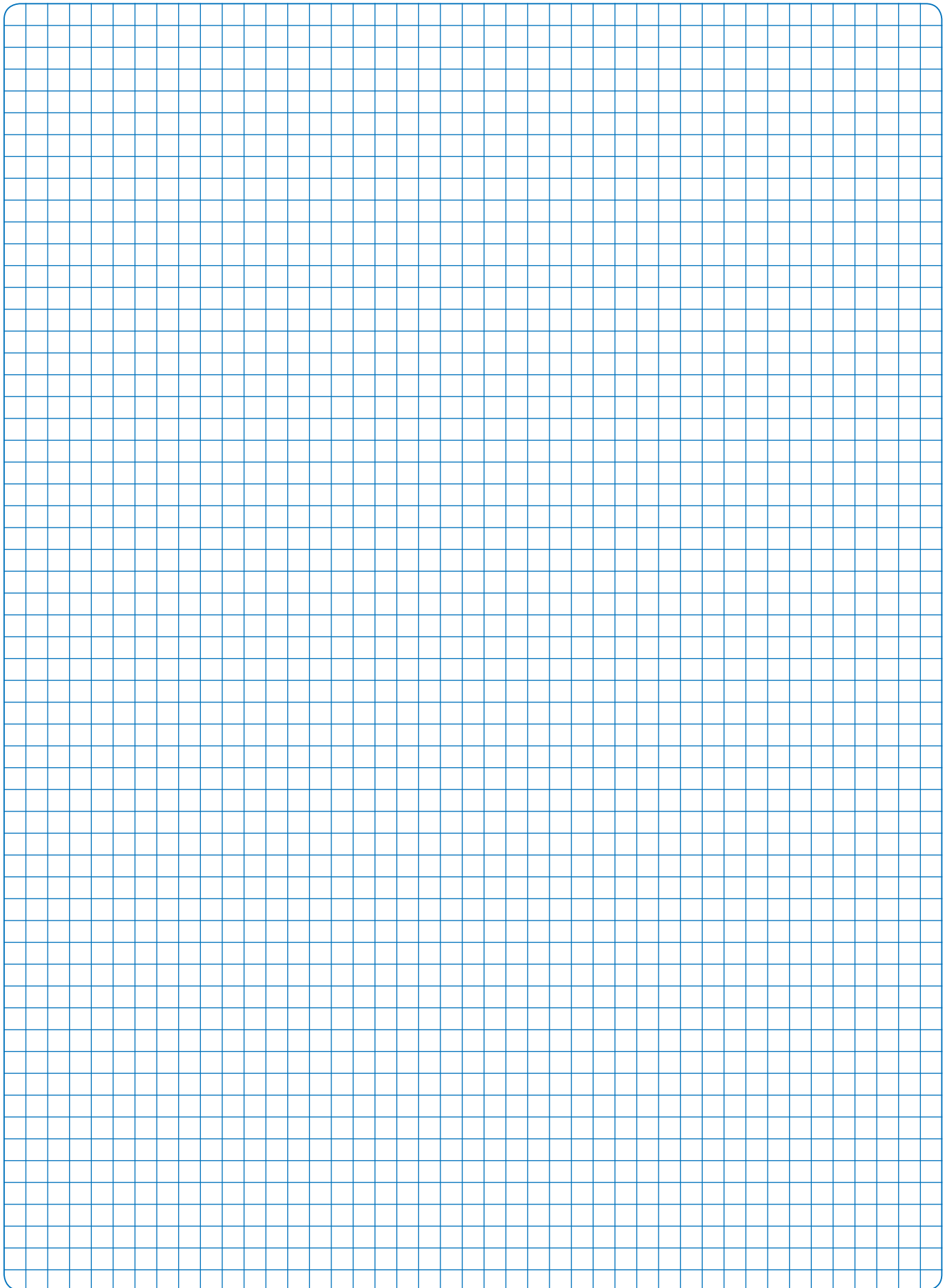

Design calculation and inquiry form

Customer and project information

Company name

Address

Contact name Phone number

Email Website

Project name

Application type

Short description of application
(please attach a sketch if possible)

Annual ball screw requirements
and start of production date

Prototype requirements
and suitable delivery date

For existing or modified application,
type of ball screw already used

Ball screw data

Design parameter	Value
Maximum stroke [mm]
Threaded length [mm]
Total length [mm]
Pre-selection of screw shaft nominal diameter d_0 [mm]
Pre-selection of lead P_h [mm]
Pre-selection of nut type
Lead precision grade according to ISO 3408
Pre-selection of axial play, backlash elimination or preload
If axial play is selected, preferred min/max range [μm]
Request for accessories (flanges, support bearings, etc.)
Other pertinent information

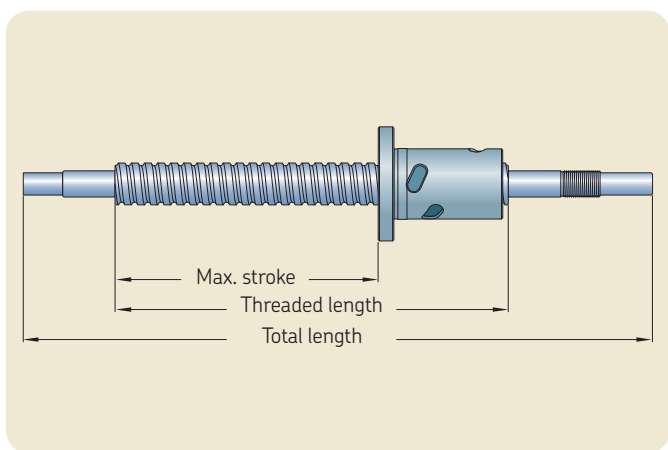

Operating conditions

Maximum loads	• Maximum static load or shock load [N]
	• Maximum dynamic load in tension [N]
	• Maximum dynamic load in compression [N]
	• Average linear speed [m/min]
	• Maximum linear speed [m/min]
	• Maximum acceleration [m/s ²]
Lubrication	• Brand name
	• Type
	• Viscosity at average operating temperature [Cst]
Operating temperature	• Minimum [°C]
	• Average [°C]
	• Maximum [°C]
Required service life	• Travel [m]
	• Or revolutions [rev]
	• Or duration [hours]

Duty cycle description

Step	Axial force [N]	Speed, either rotational speed [rpm] or linear speed [m/minute]	Travel [mm]
1
2
3
4
5
Etc.



Mounting conditions

Position of the screw	<input type="checkbox"/> Vertical	<input type="checkbox"/> Horizontal
Rotating part	<input type="checkbox"/> Screw	<input type="checkbox"/> Nut
Screw end fixing conditions	<input type="checkbox"/>	(fixed, free)
	<input type="checkbox"/>	(fixed, radial support)
	<input type="checkbox"/>	(fixed, fixed)

Other pertinent information

.....

.....

.....

.....

Ball screw catalogue, ball screw 2D prints and 3D models are available on www.skf.com
 Please send inquiry form to your SKF sales office. For contact information, please visit www.skf.com

Designation system

Complete rolled ball screw assembly

SN 32x5 R 330/445 G7 L - HA + K **/** WPR

Nut type

- SD = Miniature screw, axial play, recirculation by inserts
- BD = Miniature screw, backlash elimination, recirculation by inserts
- SH = Miniature screw, axial play, recirculation by integrated tube
- SDS = Miniature screw, axial play, stainless steel
- BDS = Miniature screw, backlash elimination, stainless steel
- SHS = Miniature screw, axial play, stainless steel, recirculation by integrated tube
- SX = Universal screw, axial play
- BX = Universal screw, backlash elimination
- SND = Precision screw, axial play, DIN nut
- BND = Precision screw, backlash elimination, DIN nut
- PND = Precision screw, preloaded, DIN nut
- SN = Precision screw, axial play, cylindrical flange
- BN = Precision screw, backlash elimination, cylindrical flange
- PN = Precision screw, preloaded, cylindrical flange
- SL = Long lead screw, axial play
- TL = Long lead screw, backlash elimination
- SLD = Long lead screw, axial play, DIN nut
- TLD = Long lead screw, backlash elimination, DIN nut
- SLT = Rotating nut, axial play
- TLT = Rotating nut, backlash elimination

Nominal diameter × Lead [mm]

Hand

- R = Right
- L = Left (on request)

Threaded length / Total length [mm]

Lead precision G5, G7, G9

Nut orientation

- Nut threaded nose or nut flange towards shorter machined end of shaft (S)
- Nut threaded nose or nut flange towards longer machined end of shaft (L)
- In case of identical machining at both shaft ends (-)

Machined end combination

See page 36

Required lengths for AA, SA, UA (both ends)

See page 36

Options

- WPR = with wipers
- NOWPR = without wipers
- RING = safety ring (for miniature ball screws only)
- REDPLAY = reduced axial play

Roller screws, electromechanical cylinders and guiding solutions



Planetary roller screws

The robust screws for long service life through tough conditions
 $d_0 = 8$ to 240 mm
 $P_h = 2$ to 50 mm
 High load carrying capacity
 Ability to survive occasional shock loads
 High reliability, even in hostile environment
 High rotational speed capability
 Beyond the capabilities of ball screws for ultimate driving performance.



Recirculating roller screws

The fine screws for ultimate positioning accuracy
 $d_0 = 8$ to 125 mm
 $P_h = 0,6$ to 5 mm
 Fine resolution for high precision
 High rigidity
 Ideal combination of small lead, high load carrying capacity and axial stiffness for ultra-precision driving solutions.



Electromechanical cylinders (EMC and CEMC types)

The high performance electromechanical cylinders incorporate SKF planetary roller screws driven by brushless motors
 Dynamic load capacity up to 450 kN
 Linear speed up to 1,6 m/s
 They are designed for long service life, high acceleration, high force applications and heavy duty cycles
 Compact Electromechanical cylinders (CEMC) deliver a unique combination of design flexibility and powerful actuation within a compact package
 SKF electromechanical cylinders using roller screws are expanding the limits of linear actuators.



Linear ball bearings

The cost-efficient guiding solution
 Dimensions according to ISO 10285 series 1 and 3, from nominal diameter 5 mm to 80 mm
 Closed and open designs, rigid and self-aligning designs. Integrated lubricant reservoir. Stainless steel option
 Wide range of accessories stocked at SKF such as linear ball bearing housings, ground shafts, shaft supports and shaft blocks
 Load carrying capacity and sealing performance optimized for maximum service life.

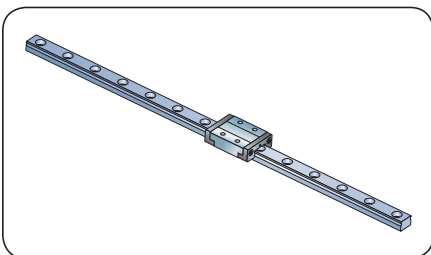

Miniature profile rail guides

The compact high precision profile rail guide for space saving and reduced machine weight
 Sizes 7 to 15 with interchangeability to DIN 645-2
 Standard width rail and larger rail for increased moment carrying capacity
 High precision-ground raceways and carriages with two rows of balls offering high load carrying capacity in all four radial directions
 Stainless steel components and factory pre-lubrication for high reliability.

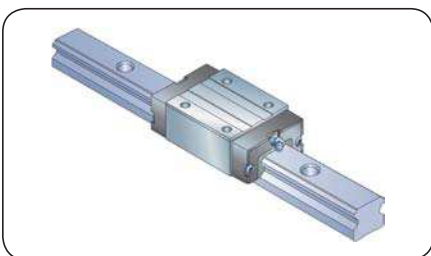

Profile rail guides

The ideal guiding solution in combination with driving by precision rolled ball screws in most machinery
 Rail sizes 15 to 45 with interchangeability to DIN 645-1 and upcoming ISO 12090-1. Variety of carriage types according to industry standards
 High precision profile rail guide with precision-ground raceways and carriages, available with various classes of precision and preload
 4 bearing raceways with X-arrangement providing equal load carrying capacity in all four radial directions, and ability to resist over-turning moments
 Accessories stocked at SKF such as low friction seals, scrapper seals, bellows, lubrication systems, etc.
 Solutions adapted to various types of applications and requirements.



© SKF is a registered trademark of the SKF Group.

© SKF Group 2013

The contents of this publication are the copyright of the publisher and may not be reproduced (even extracts) unless prior written permission is granted. Every care has been taken to ensure the accuracy of the information contained in this publication but no liability can be accepted for any loss or damage whether direct, indirect or consequential arising out of the use of the information contained herein.

Previous catalogues, in which the data deviate from those given here, are rendered invalid. The right is reserved to make changes necessitated by technological developments.

PUB MT/P1 06971/1 EN · August 2013

Certain images used under license from Shutterstock.com