



### Ausbaukupplung mit SPLIT-Naben



Piktogrammlegende ist auf dem Klapper am Umschlag zu finden



#### Bauteile

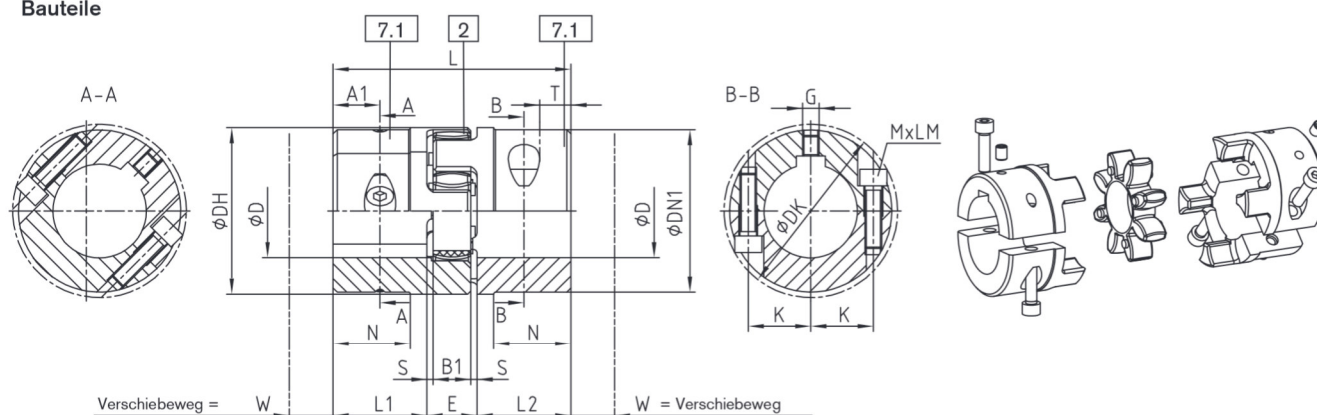

Bauart SH

#### ROTEX® Bauart SH Sinterstahl (Sinter)

Größe	Fertigbohrung D		Abmessungen [mm]													Zylinderschrauben DIN EN ISO 4762		
	min.	max.	L	L1, L2	E	B1	S	DH	DN1	DK	N	K	A1	T	G	W	MxLM	Anziehdrehmoment T <sub>A</sub> [Nm]
24	0	28	78	30	18	14	2,0	55	-	57,5	-	20	15	10	M5	12	M6x20	14
28	0	38	90	35	20	15	2,5	65	-	73	-	25	17,5	15	M8	12	M8x25	34

#### ROTEX® Bauart SH Grauguss (GJL)

Größe	Fertigbohrung D		Abmessungen [mm]													Zylinderschrauben DIN EN ISO 4762		
	min.	max.	L	L1, L2	E	B1	S	DH	DN1	DK	N	K	A1	T	G	W	MxLM	Anziehdrehmoment T <sub>A</sub> [Nm]
38	24	45	114	45	24	18	3,0	80	78	83,5	37	30	22,5	15		15	M8x30	34
42	24	55	126	50	26	20	3,0	95	94	97	40	30	25		M8	15	M10x35	67
48	24	60	140	56	28	21	3,5	105	104	108,5	45	35	28			15	M12x40	115
55	24	70	160	65	30	22	4,0	120	118	122	52	40	32,5	20		15	M12x45	115
65	28	70	185	75	35	26	4,5	135	115	123,5	61	45	37,5		M10	15	M12x40	115
	70	80							135	132,5								
75	40	80	210	85	40	30	5,0	160	135	147	69	51	42,5	25		20	M16x50	290
	80	90							160	158								
90	40	90	245	100	45	34	5,5	200	160	176	81	60	50	30	M12	20	M20x60	560
	90	110							200	197								

7.1 = SPLIT-Nabe mit Passfedernut

Bestell- beispiel:	ROTEX® 38	SH	98 ShA	7.1	Ø38	7.1	Ø30
		Kupplungsgröße	Bauart	Zahnkranzhärte	Nabenausführung	Fertigbohrung	Nabenausführung